

OPERATING INSTRUCTIONS

EN

Original

HILOBE 1004 | 1304 | 2104

Roots pump

PFEIFFER  VACUUM



Dear Customer,

Thank you for choosing a Pfeiffer Vacuum product. Your new roots pump should support you in your individual application with full performance and without malfunctions. The name Pfeiffer Vacuum stands for high-quality vacuum technology, a comprehensive and complete range of top-quality products and first-class service. From this extensive, practical experience we have gained a large volume of information that can contribute to efficient deployment and to your personal safety.

In the knowledge that our product must avoid consuming work output, we trust that our product can offer you a solution that supports you in the effective and trouble-free implementation of your individual application.

Please read these operating instructions before putting your product into operation for the first time. If you have any questions or suggestions, please feel free to contact info@pfeiffer-vacuum.de.

Further operating instructions from Pfeiffer Vacuum can be found in the [Download Center](#) on our website.

Disclaimer of liability

These operating instructions describe all models and variants of your product. Note that your product may not be equipped with all features described in this document. Pfeiffer Vacuum constantly adapts its products to the latest state of the art without prior notice. Please take into account that online operating instructions can deviate from the printed operating instructions supplied with your product.

Furthermore, Pfeiffer Vacuum assumes no responsibility or liability for damage resulting from the use of the product that contradicts its proper use or is explicitly defined as foreseeable misuse.

Copyright

This document is the intellectual property of Pfeiffer Vacuum and all contents of this document are protected by copyright. They may not be copied, altered, reproduced or published without the prior written permission of Pfeiffer Vacuum.

We reserve the right to make changes to the technical data and information in this document.



Table of contents

1	About this manual	7
1.1	Validity	7
	1.1.1 Applicable documents	7
	1.1.2 Variants	7
1.2	Target group	7
1.3	Conventions	7
	1.3.1 Instructions in the text	7
	1.3.2 Pictographs	8
	1.3.3 Stickers on the product	8
	1.3.4 Abbreviations	10
2	Safety	11
2.1	General safety instructions	11
2.2	Safety instructions	11
2.3	Safety precautions	14
2.4	Limits of use	15
2.5	Proper use	15
2.6	Foreseeable misuse	16
2.7	Personnel qualification	16
	2.7.1 Ensuring personnel qualification	16
	2.7.2 Personnel qualification for maintenance and repair	17
	2.7.3 Advanced training with Pfeiffer Vacuum	17
3	Product description	18
3.1	Function	18
	3.1.1 Drive	19
	3.1.2 Cooling	20
	3.1.3 Mounting orientations	20
3.2	Identifying the product	20
3.3	Product features	20
3.4	Scope of delivery	20
4	Transportation and Storage	21
4.1	Transporting the vacuum pump	21
4.2	Storing the vacuum pump	22
5	Installation	23
5.1	Installing the vacuum pump	23
5.2	Mounting orientations	23
5.3	Filling with lubricant	24
5.4	Connecting the vacuum side	25
5.5	Connecting the fore-vacuum side	26
5.6	Connect the switch box	27
5.7	Connect the temperature sensors and fan	28
5.8	Establishing mains connection	28
6	Interfaces	30
6.1	"Remote" interface	30
	6.1.1 Voltage output	30
	6.1.2 Inputs	31
	6.1.3 Outputs	31
	6.1.4 RS-485	31
6.2	Interface RS-485	31
6.3	Pfeiffer Vacuum protocol for RS-485 interface	32
	6.3.1 Telegram frame	32
	6.3.2 Telegram description	33
	6.3.3 Telegram example 1	33

	6.3.4 Telegram example 2	33
	6.3.5 Data types	34
7	Parameter set	35
	7.1 General	35
	7.2 Control commands	35
	7.3 Status requests	36
	7.4 Set value settings	37
	7.5 Additional parameter for the DCU	37
8	Operation	38
	8.1 Putting the vacuum pump into operation	38
	8.2 Switching on the vacuum pump	38
	8.3 Configuring the connections with the Pfeiffer Vacuum parameter set	38
	8.4 Operating modes	39
	8.4.1 Normal operation	39
	8.4.2 Stand-by operation	40
	8.4.3 Operation speed setting mode	40
	8.5 Operation monitoring	40
	8.5.1 Operating mode display via LED	40
	8.5.2 Temperature monitoring	40
	8.5.3 Checking the lubricant level	41
	8.6 Switching off and venting	41
9	Maintenance	42
	9.1 Maintenance information	42
	9.2 Checklist for inspection and maintenance	42
	9.3 Cleaning the air filter	43
	9.4 Changing the lubricant	44
	9.4.1 Draining the lubricant	44
	9.4.2 Filling the lubricant	45
10	Decommissioning	47
	10.1 Shutting down for longer periods	47
	10.2 Recommissioning	47
	10.3 Disposing of the vacuum pump	47
11	Malfunctions	48
	11.1 General	48
	11.2 Troubleshooting	48
	11.3 Error codes	49
	11.4 Warning and error messages when operating with DCU	49
12	Service solutions from Pfeiffer Vacuum	51
13	Ordering spare parts packs	53
14	Accessories	54
	14.1 Accessory information	54
	14.2 Ordering accessories	54
15	Technical data and dimensions	56
	15.1 General	56
	15.2 Substances in contact with the media	56
	15.3 Technical data	56
	15.4 Dimensions	58
	Declaration of conformity	61



List of tables

Tbl. 1:	Stickers on the product	9
Tbl. 2:	Abbreviations used	10
Tbl. 3:	Permissible ambient conditions	15
Tbl. 4:	Features of the roots pumps	20
Tbl. 5:	Plug arrangement of the D-Sub socket, 15-pin	30
Tbl. 6:	Features of the RS-485 interface	32
Tbl. 7:	Explanation and meaning of the parameters	35
Tbl. 8:	Parameter set Control commands	36
Tbl. 9:	Parameter set Status requests	36
Tbl. 10:	Parameter set Reference value inputs	37
Tbl. 11:	Parameter for DCU functions	37
Tbl. 12:	Configuration with parameters [P:019] and [P:024]	39
Tbl. 13:	Configuration with parameters [P:060] and [P:061]	39
Tbl. 14:	Meaning of the LEDs	40
Tbl. 15:	Maintenance intervals	43
Tbl. 16:	Troubleshooting	48
Tbl. 17:	Error messages of the electronic drive unit	49
Tbl. 18:	Warning messages of the electronic drive unit	49
Tbl. 19:	Warning and error messages when using a DCU	50
Tbl. 20:	HiLobe spare parts packs	53
Tbl. 21:	Accessories	54
Tbl. 22:	Consumables	55
Tbl. 23:	Conversion table: Pressure units	56
Tbl. 24:	Conversion table: Units for gas throughput	56
Tbl. 25:	Materials that make contact with the process media	56
Tbl. 26:	Technical data HiLobe vertical direction of flow	57
Tbl. 27:	Technical data HiLobe horizontal direction of flow	58

List of figures

Fig. 1:	Position of stickers on product with vertical direction of flow	9
Fig. 2:	Position of stickers on product with horizontal direction of flow	10
Fig. 3:	Max. permissible pressure differential between input and output sides, in accordance with pump rotation speed	15
Fig. 4:	Design, vertical direction of flow	18
Fig. 5:	Design, horizontal direction of flow	19
Fig. 6:	Design, switch box	19
Fig. 7:	Transporting the vacuum pump	22
Fig. 8:	Mounting orientation: Vertical direction of flow	23
Fig. 9:	Mounting orientation: Horizontal direction of flow	24
Fig. 10:	Filling with lubricant	25
Fig. 11:	Connect the switch box	27
Fig. 12:	Connect the extension cable	28
Fig. 13:	Mains connection pin assignment	29
Fig. 14:	Pin assignment of the D-Sub socket, 15-pin	30
Fig. 15:	Cross-link via connection RS-485 using connection cables and accessories	32
Fig. 16:	Replace the baffle strainer of the fan	43
Fig. 17:	Drain the lubricant	45
Fig. 18:	Filling with lubricant	46
Fig. 19:	HiLobe 1004, HiLobe 1304, HiLobe 2104 DN 100	59
Fig. 20:	RC 4000 electronic drive unit	60



1 About this manual



IMPORTANT

Read carefully before use.
Keep the manual for future consultation.

1.1 Validity

These operating instructions are for customers of Pfeiffer Vacuum. They describe the function of the designated product and provide the most important information for safe usage of the product. The descriptions comply with applicable directives. All information provided in these operating instructions refer to the current development status of the product. The documentation remains valid as long as the customer does not modify the product in any way.

1.1.1 Applicable documents

Document	Number
Declaration of conformity	A component of these instructions

You can find this document in the [Pfeiffer Vacuum Download Center](#).

1.1.2 Variants

- HiLobe 1004
- HiLobe 1304
- HiLobe 2104
- HiLobe 1004 H
- HiLobe 1304 H
- HiLobe 2104 H

1.2 Target group

These operating instructions are aimed at all persons performing the following activities on the product:

- Transportation
- Setup (Installation)
- Usage and operation
- Decommissioning
- Maintenance and cleaning
- Storage or disposal

The work described in this document is only permitted to be performed by persons with the appropriate technical qualifications (expert personnel) or who have received the relevant training from Pfeiffer Vacuum.

1.3 Conventions

1.3.1 Instructions in the text

Usage instructions in the document follow a general structure that is complete in itself. The required action is indicated by an individual step or multi-part action steps.

Individual action step

A horizontal, solid triangle indicates the only step in an action.

- ▶ This is an individual action step.

Sequence of multi-part action steps

The numerical list indicates an action with multiple necessary steps.

1. Step 1
2. Step 2
3. ...

1.3.2 Pictographs

Pictographs used in the document indicate useful information.



Note



Tip

1.3.3 Stickers on the product

This section describes all the stickers on the product along with their meaning.

	<p>Rating plate (example)</p> <p>The rating plate for the vacuum pump is located on the front of the vacuum pump drive.</p>
	<p>Rating plate of the electronic drive unit</p> <p>The rating plate is located on the switch box of the electronic drive unit.</p>
	<p>Mains power supply</p> <p>This sticker indicates that you must use the original power supply connector.</p>
	<p>Operating instructions note</p> <p>This sticker indicates that this operating instructions must be read before performing any tasks.</p>
	<p>Warning hot surface</p> <p>This sticker warns of injuries caused by high temperatures in case of touching without protection during operation.</p>



<p>warranty seal PFEIFFER VACUUM</p>	<p>Closure seal The product is sealed ex-factory. Damaging or removing a closure seal results in loss of the warranty.</p>
	<p>Oil can The "Oil can" sticker indicates the filler screws for lubricant.</p>

Tbl. 1: Stickers on the product

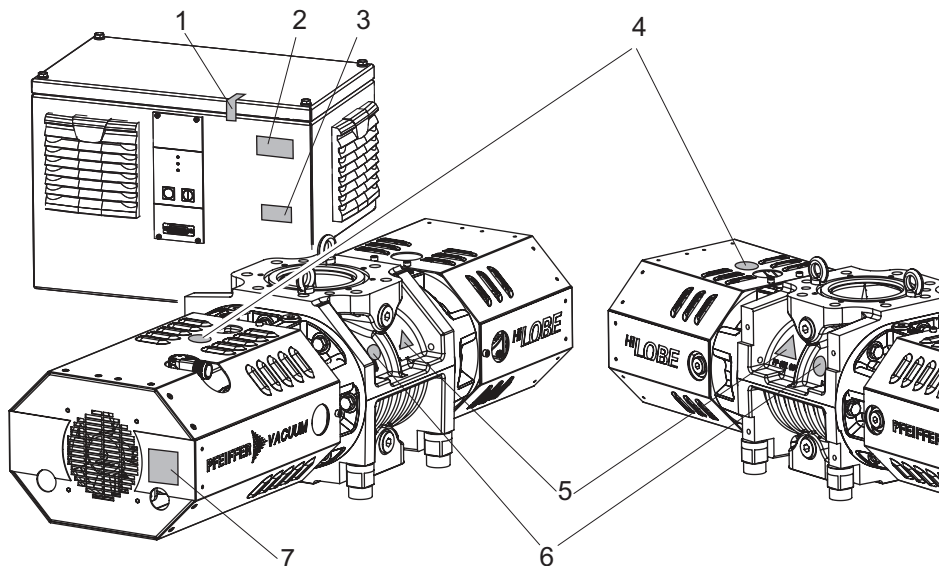

Fig. 1: Position of stickers on product with vertical direction of flow

- | | |
|---|---|
| 1 Closure seal | 5 Warning notice: hot surface |
| 2 Rating plate of the electronic drive unit | 6 Note: Read the operating instructions |
| 3 Note: Original power supply connector | 7 Rating plate of the vacuum pump |
| 4 Note: Filling ports for lubricant | |



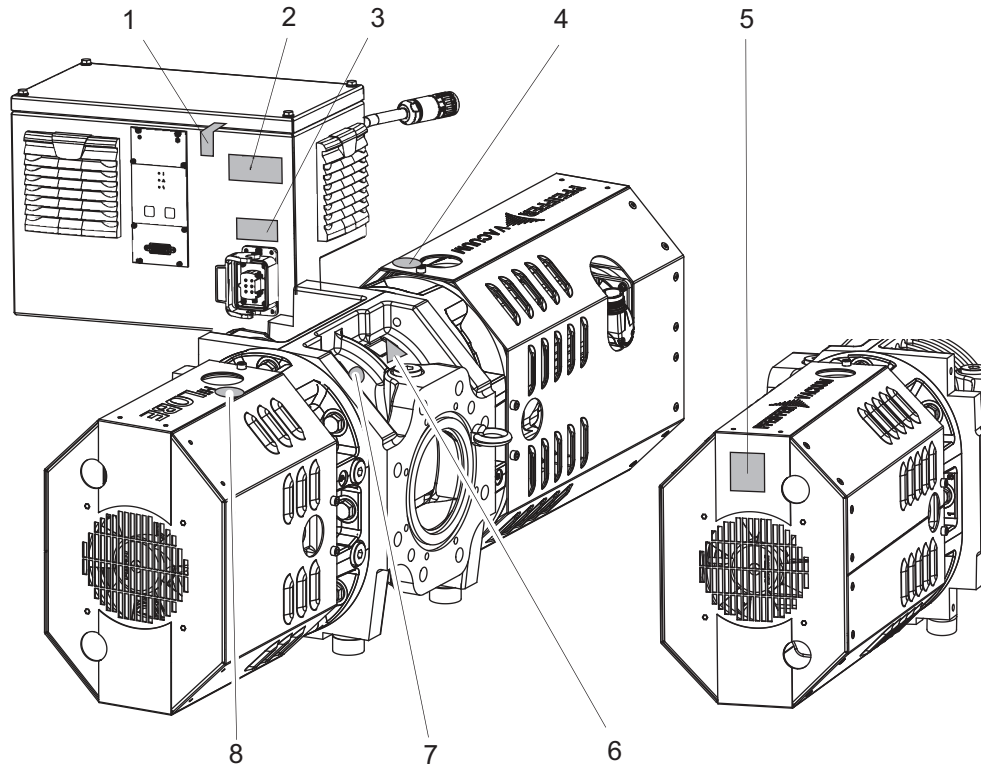

Fig. 2: Position of stickers on product with horizontal direction of flow

- | | |
|---|---|
| 1 Closure seal | 5 Rating plate of the vacuum pump |
| 2 Rating plate of the electronic drive unit | 6 Warning notice: hot surface |
| 3 Note: Original power supply connector | 7 Note: Read the operating instructions |
| 4 Note: Filling ports for lubricant | 8 Note: Filling ports for lubricant |

1.3.4 Abbreviations

Abbreviation	Explanation
DCU	Display Control Unit
HPU	Handheld Programming Unit
[P:xxx]	Electronic drive unit control parameters. Printed in bold as a three-digit number in square brackets. Frequently displayed in conjunction with a short description: Example: [P:xxx] Software version
PE	Earthed conductor (protective earth)
n.c.	not connected
RS-485	Standard for a physical interface for asynchronous serial data transmission (Recommended Standard)
remote	15-pin D-Sub connecting socket on the control panel of the switch box
Ssc	Short-circuit capacity
FKM	Fluoropolymer rubber
FC	Frequency converter
BA	Operating instructions
SI	Service instructions
PV	Pfeiffer Vacuum

Tbl. 2: Abbreviations used



2 Safety

2.1 General safety instructions

This document includes the following 4 risk levels and 1 information level.

DANGER

Imminent danger

Indicates a hazardous situation which, if not avoided, will result in death or serious injury.

- ▶ Instructions on avoiding the hazardous situation

WARNING

Possibly imminent danger

Indicates a hazardous situation which, if not avoided, could result in death or serious injury.

- ▶ Instructions on avoiding the hazardous situation

CAUTION

Possibly imminent danger

Indicates a hazardous situation which, if not avoided, could result in minor or moderate injury.

- ▶ Instructions on avoiding the hazardous situation

NOTICE

Danger of property damage

Notice is used to address practices not related to physical injury.

- ▶ Instructions on avoiding property damage



Notes, tips or examples indicate important information on the product or on this document.

2.2 Safety instructions

All safety instructions in this document are based on the results of the risk assessment carried out in accordance with Machinery Directive 2006/42/EC Annex I and EN ISO 12100 Section 5. Where applicable, all life cycle phases of the product were taken into account.

Risks during transport

WARNING

Risk of serious injury from swinging, toppling or falling objects

During transport, there is a risk of crushing and impact on swinging, toppling or falling objects. There is a risk of injuries to limbs, up to and including bone fractures and head injuries.

- ▶ Secure the danger zone if necessary.
- ▶ Pay attention to the center of gravity of the load during transport.
- ▶ Ensure even movements and moderate speeds.
- ▶ Observe safe handling of the transport devices.
- ▶ Avoid sloping attachment aids.
- ▶ Never stack products.
- ▶ Wear protective equipment, e.g. safety shoes.



Risks during installation

⚠ DANGER

Danger to life from electric shock

Contact with exposed and live elements generate an electric shock. Incorrect connection of the mains supply leads to the risk of live housing parts that can be touched. There is a risk to life.

- ▶ Before the installation, check that the connection leads are voltage-free.
- ▶ Make sure that electrical installations are only carried out by qualified electricians.
- ▶ Provide adequate grounding for the device.
- ▶ After connection work, do a PE conductor check.

⚠ DANGER

Danger to life from electric shock

When establishing the voltages that exceed the specified safety extra-low voltage (according to IEC 60449 and VDE 0100), the insulating measures will be destroyed. There is a danger to life from electric shock at the communication interfaces.

- ▶ Connect only suitable devices to the bus system.

⚠ WARNING

Risk of danger to life through missing mains disconnection device

The vacuum pump and electronic drive unit are **not** equipped with a mains disconnection device (mains switch).

- ▶ Install a suitable motor protection switch.
- ▶ Obtain the power details for the setting value from the motor rating plate.

⚠ WARNING

Risk of fatal injury due to electric shock on account of incorrect installation

The device's power supply uses life-threatening voltages. Unsafe or improper installation can lead to life-threatening situations from electric shocks obtained from working with or on the unit.

- ▶ Ensure safe integration into an emergency off safety circuit.
- ▶ Do not carry out your own conversions or modifications on the unit.

⚠ WARNING

Risk of crushing from rotating parts

Fingers and hands may be caught by rotating pistons within the connection flange. This results in severe injuries.

- ▶ Keep limbs out of the reach of the roots pump.

⚠ CAUTION

Danger of injury from bursting as a result of high pressure in the exhaust line

Faulty or inadequate exhaust pipes lead to dangerous situations, e.g. increased exhaust pressure. There is a danger of bursting. Injuries caused by flying fragments, the escaping of high pressure, and damage to the unit cannot be excluded.

- ▶ Route the exhaust line without shut-off units.
- ▶ Observe the permissible pressures and pressure differentials for the product.
- ▶ Check the function of the exhaust line on a regular basis.



⚠ CAUTION**Electric shock and damage to the vacuum pump and electronic drive unit due to improper connection and disconnection of components**

With existing power supply connection to the switch box, there is a risk of electric shock when making contact with the motor connecting plug. Even after the power supply has been switched off, the vacuum pump continues to deliver electrical energy during its run-down period. If the units are disconnected prematurely, there is the risk of electric shock, and destruction of electric components.

- ▶ Always interrupt the power supply connection at the switch box before connecting the power supply plug to the motor.
- ▶ With existing power supply connection to the switch box or when the pistons are running, never disconnect the motor connecting plug.
- ▶ After switching off, wait at least another 5 minutes until the capacitors have discharged before separating the cable connection.

Risks during operation**⚠ WARNING****Danger of poisoning due to toxic process media escaping from the exhaust pipe**

During operation with no exhaust line, the vacuum pump allows exhaust gases and vapors to escape freely into the air. There is a risk of injury and fatality due to poisoning in processes with toxic process media.

- ▶ Observe the pertinent regulations for handling toxic process media.
- ▶ Safely purge toxic process media via an exhaust line.
- ▶ Use appropriate filter equipment to separate toxic process media.

⚠ CAUTION**Danger of injury from bursting as a result of high pressure in the exhaust line**

Faulty or inadequate exhaust pipes lead to dangerous situations, e.g. increased exhaust pressure. There is a danger of bursting. Injuries caused by flying fragments, the escaping of high pressure, and damage to the unit cannot be excluded.

- ▶ Route the exhaust line without shut-off units.
- ▶ Observe the permissible pressures and pressure differentials for the product.
- ▶ Check the function of the exhaust line on a regular basis.

Risks during maintenance, decommissioning and in event of malfunctions**⚠ WARNING****Danger to life from electric shock during maintenance and service work**

There is a danger to life from electric shock when making contact with live components that still exist after the vacuum pump has been switched off.

- ▶ Disconnect the vacuum pump safely from the mains.
- ▶ Wait until the vacuum pump comes to a standstill (rotation speed = 0).
- ▶ After switching off the vacuum pump, wait another 5 minutes until the capacitors have discharged.

⚠ WARNING**Danger to life from electric shock in the event of a fault**

In the event of a fault, devices connected to the mains may be live. There is a danger to life from electric shock when making contact with live components.

- ▶ Always keep the mains connection freely accessible so you can disconnect it at any time.



⚠ WARNING

Risk of crushing from rotating parts

Fingers and hands may be caught by rotating pistons within the connection flange. This results in severe injuries.

- ▶ Keep limbs out of the reach of the roots pump.

⚠ WARNING

Health hazard through poisoning from toxic contaminated components or devices

Toxic process media result in contamination of devices or parts of them. During maintenance work, there is a risk to health from contact with these poisonous substances. Illegal disposal of toxic substances causes environmental damage.

- ▶ Take suitable safety precautions and prevent health hazards or environmental pollution by toxic process media.
- ▶ Decontaminate affected parts before carrying out maintenance work.
- ▶ Wear protective equipment.

⚠ CAUTION

Scalding from hot lubricant

Danger of scalding when draining lubricant if it comes into contact with the skin.

- ▶ Wear protective equipment.
- ▶ Use a suitable collection receptacle.

2.3 Safety precautions

i

Duty to provide information on potential dangers

The product holder or user is obliged to make all operating personnel aware of dangers posed by this product.

Every person who is involved in the installation, operation or maintenance of the product must read, understand and adhere to the safety-related parts of this document.

i

Infringement of conformity due to modifications to the product

The Declaration of Conformity from the manufacturer is no longer valid if the operator changes the original product or installs additional equipment.

- Following the installation into a system, the operator is required to check and re-evaluate the conformity of the overall system in the context of the relevant European Directives, before commissioning that system.

General safety precautions

- ▶ Do not expose body parts to the vacuum.
- ▶ Observe the safety and accident prevention regulations, if necessary wear personal protective equipment.
- ▶ Check all safety measures at regular intervals.
- ▶ Always ensure a secure connection to the earthed conductor (PE), protection class I.
- ▶ During operation, make sure that plug-and-socket connections are securely fitted.
- ▶ Never operate the vacuum pump with open vacuum flange.
- ▶ Never make your own conversions or modifications to the vacuum pump.
- ▶ Before returning the vacuum pump, observe the notes in the chapter Service.



2.4 Limits of use

Parameter	HiLobe
Installation location	<ul style="list-style-type: none"> • Indoors: protected from dust deposits • Outdoors: dry, protected from direct weather influences such as <ul style="list-style-type: none"> – strong air drafts – rain and splashed water
Installation altitude	max. 2000 m above sea level ¹⁾
Installation surface flatness	horizontal, max. permissible angle of inclination: $\pm 3^\circ$
Ambient temperature	+5 °C to +40 °C
Relative air humidity	max. 85 %
Permanent intake pressure in circulation mode	< 1100 hPa (abs.)
Max. pressure differential in circulation mode	80 hPa
Max. speed in circulation mode	4200 rpm
Permanent intake pressure in vacuum mode	depending on max. pressure differential
Max. gas temperature, pressure side	250 °C

Tbl. 3: Permissible ambient conditions

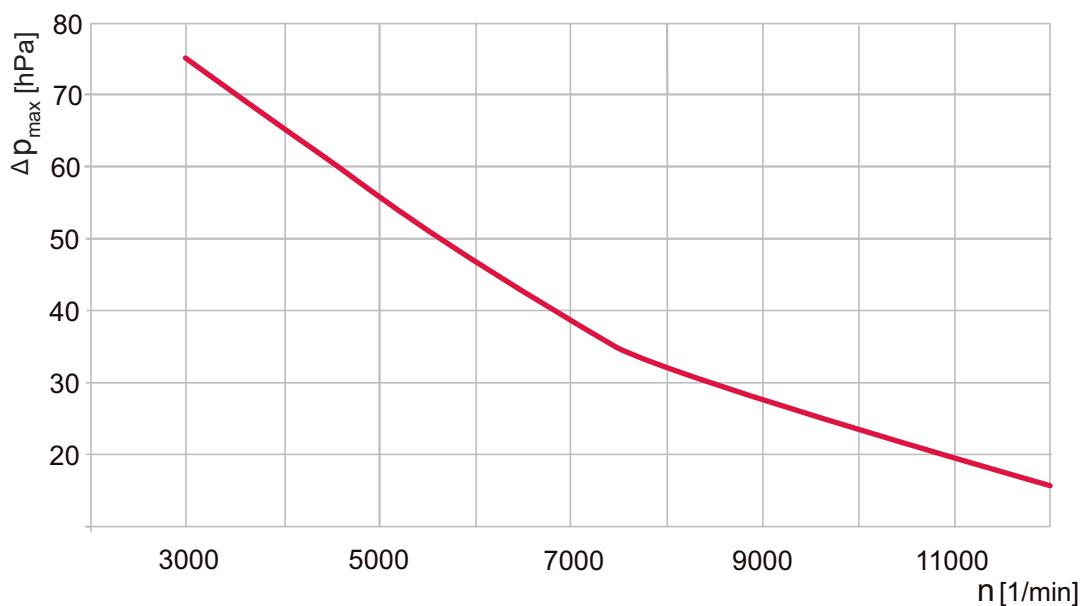

Fig. 3: Max. permissible pressure differential between input and output sides, in accordance with pump rotation speed

2.5 Proper use

- ▶ Use the vacuum pump for vacuum generation only.
- ▶ To protect the lubricant and the bearing, use sealing gas if high boiling or corrosive media (e.g. solvents) are pumped.
- ▶ Operate the vacuum pump within the application limits of the product and in compliance with the technical data.
- ▶ Adhere to the installation, commissioning, operating, and maintenance instructions.
- ▶ Use only accessory parts recommended by Pfeiffer Vacuum.

1) at installation altitudes > 1,000m above m.s.l. and an ambient temperature of 40 °C the rated power of the motor reduces by around 10 %



2.6 Foreseeable misuse

Misuse of the product invalidates all warranty and liability claims. Any use that is counter to the purpose of the product, whether intentional or unintentional, is regarded as misuse.

- Pumping explosive media
- Pumping media that can corrode or not be withstood by the vacuum pump materials
- Pumping media that introduce an ignition source to the suction chamber
- Pumping media that form adhesive deposits inside the suction chamber and cause the pistons to touch or jam
- Pumping pressurized media (> atmospheric pressure)
- Pumping fluids that do not serve cleaning
- Pumping radioactive media
- Pumping media prone to spontaneous, specific exothermic reactions
- Use in potentially explosive areas
- Use in systems in which the equipment is subjected to dynamic loads and vibrations or periodic forces
- Use in strong electrical, magnetic, or electromagnetic fields
- Use with vacuum and/or fore-vacuum flange open to the atmosphere
- Modification of frequency converter parameters in the electronic drive unit
- Using lubricants not specified by Pfeiffer Vacuum
- Using pipes to lift the vacuum pump
- Use of accessories or spare parts that are not listed in these instructions
- Using the vacuum pump as a climbing aid
- Use of mineral-based lubricants, such as P3, with an oxygen concentration > 21 %

Mineral-based lubricants are combustible and ignite at high temperatures, and when they come into contact with pure oxygen. These lubricants oxidize heavily and thus lose their lubricating capacity.

2.7 Personnel qualification

The work described in this document may only be carried out by persons who have appropriate professional qualifications and the necessary experience or who have completed the necessary training as provided by Pfeiffer Vacuum.

Training people

1. Train the technical personnel on the product.
2. Only let personnel to be trained work with and on the product when under the supervision of trained personnel.
3. Only allow trained technical personnel to work with the product.
4. Before starting work, make sure that the commissioned personnel have read and understood these operating instructions and all applicable documents, in particular the safety, maintenance and repair information.

2.7.1 Ensuring personnel qualification

Specialist for mechanical work

Only a trained specialist may carry out mechanical work. Within the meaning of this document, specialists are people responsible for construction, mechanical installation, troubleshooting and maintenance of the product, and who have the following qualifications:

- Qualification in the mechanical field in accordance with nationally applicable regulations
- Knowledge of this documentation

Specialist for electrotechnical work

Only a trained electrician may carry out electrical engineering work. Within the meaning of this document, electricians are people responsible for electrical installation, commissioning, troubleshooting, and maintenance of the product, and who have the following qualifications:

- Qualification in the electrical engineering field in accordance with nationally applicable regulations
- Knowledge of this documentation

In addition, these individuals must be familiar with applicable safety regulations and laws, as well as the other standards, guidelines, and laws referred to in this documentation. The above individuals must



have an explicitly granted operational authorization to commission, program, configure, mark, and earth devices, systems, and circuits in accordance with safety technology standards.

Trained individuals

Only adequately trained individuals may carry out all works in other transport, storage, operation and disposal fields. Such training must ensure that individuals are capable of carrying out the required activities and work steps safely and properly.

2.7.2 Personnel qualification for maintenance and repair



Advanced training courses

Pfeiffer Vacuum offers advanced training courses to maintenance levels 2 and 3.

Adequately trained individuals are:

- **Maintenance level 1**
 - Customer (trained specialist)
- **Maintenance level 2**
 - Customer with technical education
 - Pfeiffer Vacuum service technician
- **Maintenance level 3**
 - Customer with Pfeiffer Vacuum service training
 - Pfeiffer Vacuum service technician

2.7.3 Advanced training with Pfeiffer Vacuum

For optimal and trouble-free use of this product, Pfeiffer Vacuum offers a comprehensive range of courses and technical trainings.

For more information, please contact [Pfeiffer Vacuum technical training](#).



3 Product description

3.1 Function

The operating principle of the **HiLobe** roots pump is based on 2 synchronous pistons that rotate in a housing without touching. The pumping effects arise as a result of the opposing rotation of the 2 figure-of-eight shaped rolling pistons. While suction chambers are formed between the rolling pistons and the housing, the rolling pistons continuously form a mutual seal without touching each other or the housing. A pair of gears positioned on the extended shaft ends, causes the opposing, synchronous running of the roots pistons. Lubrication is limited to the two bearing and gear chambers which are arranged separately from the suction chambers.

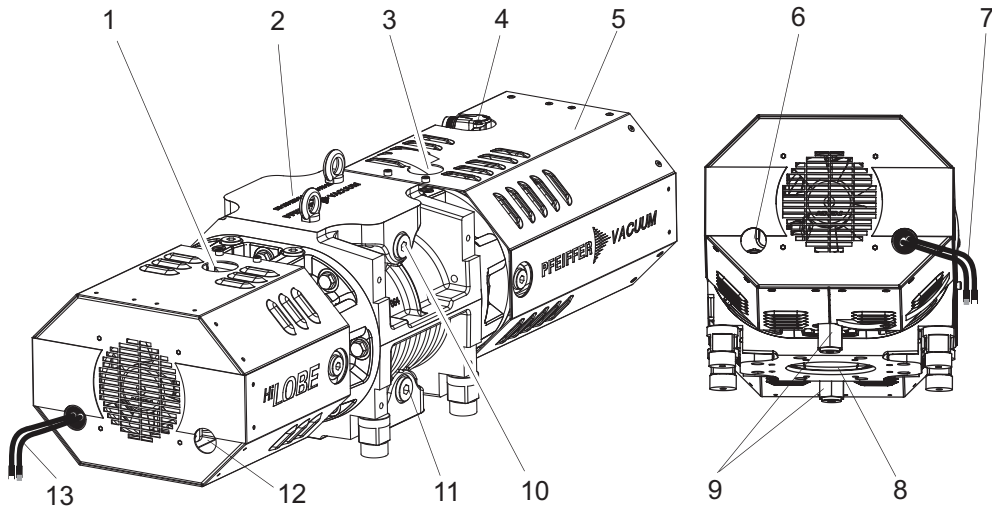

Fig. 4: Design, vertical direction of flow

- | | |
|--|---|
| 1 Filler screw | 8 Fore-vacuum flange |
| 2 Vacuum flange with flange cover (foil) | 9 Drain screw |
| 3 Filler screw | 10 Measurement connection vacuum side |
| 4 Motor power supply plug | 11 Measurement connection fore-vacuum side |
| 5 Fan cover | 12 Sight glass, opposite side |
| 6 Sight glass motor side | 13 Connecting cable, fan/temperature sensor |
| 7 Connecting cable, fan/temperature sensor | |



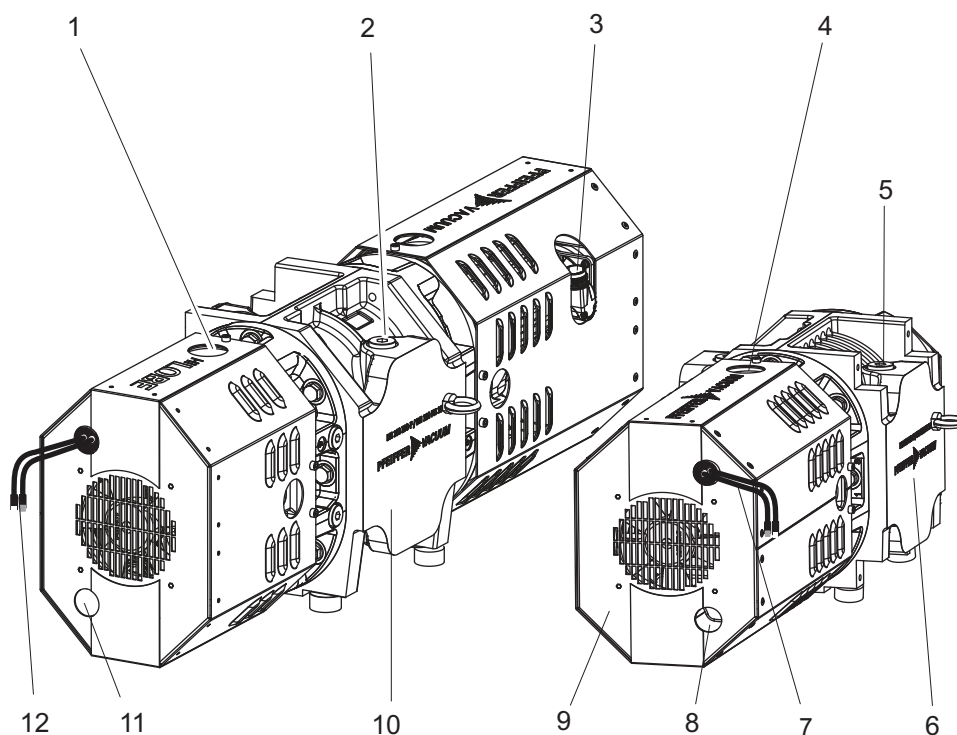

Fig. 5: Design, horizontal direction of flow

- | | |
|---|---|
| 1 Filler screw | 7 Connecting cable, fan/temperature sensor |
| 2 Measurement connection vacuum side | 8 Sight glass motor side |
| 3 Motor power supply plug | 9 Fan cover |
| 4 Filler screw | 10 Vacuum flange with flange cover (foil) |
| 5 Measurement connection fore-vacuum side | 11 Sight glass, opposite side |
| 6 Fore-vacuum flange with flange cover (foil) | 12 Connecting cable, fan/temperature sensor |

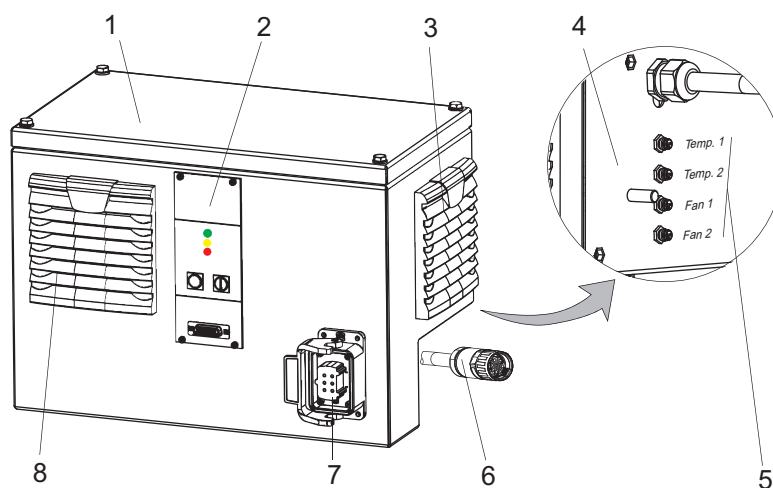

Fig. 6: Design, switch box

- | | |
|-------------------------|--|
| 1 Switch box | 5 Fan and temperature sensor connections |
| 2 Operator panel | 6 Motor connecting cable |
| 3 Venting grille, inlet | 7 Mains power supply |
| 4 Switch box rear side | 8 Venting grille, outlet |

3.1.1 Drive

The drive of the vacuum pump is carried out coupling-free in "Cantilever design". Due to the motor design, the vacuum pump is compact, hermetically sealed and also has a high efficiency. The frequency converter takes over the control of the vacuum pump and permits the adjustment of the speed to the actual process requirements (in the valid speed range).

3.1.2 Cooling

The vacuum pump is equipped with active sensor-monitored air cooling.

3.1.3 Mounting orientations

The vacuum pump is available in 2 versions; for either vertical or horizontal direction of flow. The mounting orientation is defined at the factory prior to delivery. Subsequent alteration of the mounting orientation by the user is not permissible. The oil supply is different for each version, whereby an impermissible mounting orientation will lead to deficient lubrication of the bearing.

3.2 Identifying the product

To ensure for a clear identification of the product when communicating with Pfeiffer Vacuum, always keep all of the information on the rating plate to hand.

The following information is shown on the rating plate:

- Pump model
- Model number
- Type and quantity of the lubricant
- Max. allowable pump rotation speed
- Date of manufacture
- Input voltage range

3.3 Product features

Pump type	Nominal pumping speed	Inlet/direction of flow
HiLobe 1004	520 –1050 m ³ /h	top/vertical
HiLobe 1304	520 -1300 m ³ /h	top/vertical
HiLobe 2104	520 -2100 m ³ /h	top/vertical
HiLobe 1004 H	520 –1050 m ³ /h	lateral/horizontal
HiLobe 1304 H	520 -1300 m ³ /h	lateral/horizontal
HiLobe 2104 H	520 -2100 m ³ /h	lateral/horizontal

Tbl. 4: Features of the roots pumps

3.4 Scope of delivery

- Vacuum pump with switch box and frequency converter
- Flange cover (foil) for the connection flange
- Seal for the connection flange
- Screw kit for the connection flange
- 2 ring bolts for lifting the vacuum pump
- Mating plug for the mains connection
- 2 temperature sensors
- Motor and temperature sensor extension cable, 3 m, 5 m or 10 m
- Lubricant P3 (for standard pump)
- Operating instructions



4 Transportation and Storage

4.1 Transporting the vacuum pump

WARNING

Risk of serious injury from swinging, toppling or falling objects

During transport, there is a risk of crushing and impact on swinging, toppling or falling objects. There is a risk of injuries to limbs, up to and including bone fractures and head injuries.

- ▶ Secure the danger zone if necessary.
- ▶ Pay attention to the center of gravity of the load during transport.
- ▶ Ensure even movements and moderate speeds.
- ▶ Observe safe handling of the transport devices.
- ▶ Avoid sloping attachment aids.
- ▶ Never stack products.
- ▶ Wear protective equipment, e.g. safety shoes.



Instructions for safe transport

- Only remove the flange covers for the connection flange once the pipes have been mounted.
- Fill the gear and bearing chambers with lubricant only once the final installation position is reached.



Packing

Pfeiffer Vacuum recommends storing the transport packaging.

General notes

1. Observe weight specified on the rating plate.
2. Where possible, always transport or ship the roots pump in its original packaging.
3. Remove the protective cover only immediately prior to installation.

Instructions for transport when packaged

1. Use a pallet truck to transport the vacuum pump in its packaging.
2. Note the center of gravity of the load.
3. Observe safe handling of manually operated transport devices.
4. Ensure harmonious movements and moderate speeds.
5. Ensure a flat and horizontal surface.
6. Wear personal protective equipment, e.g. safety shoes.

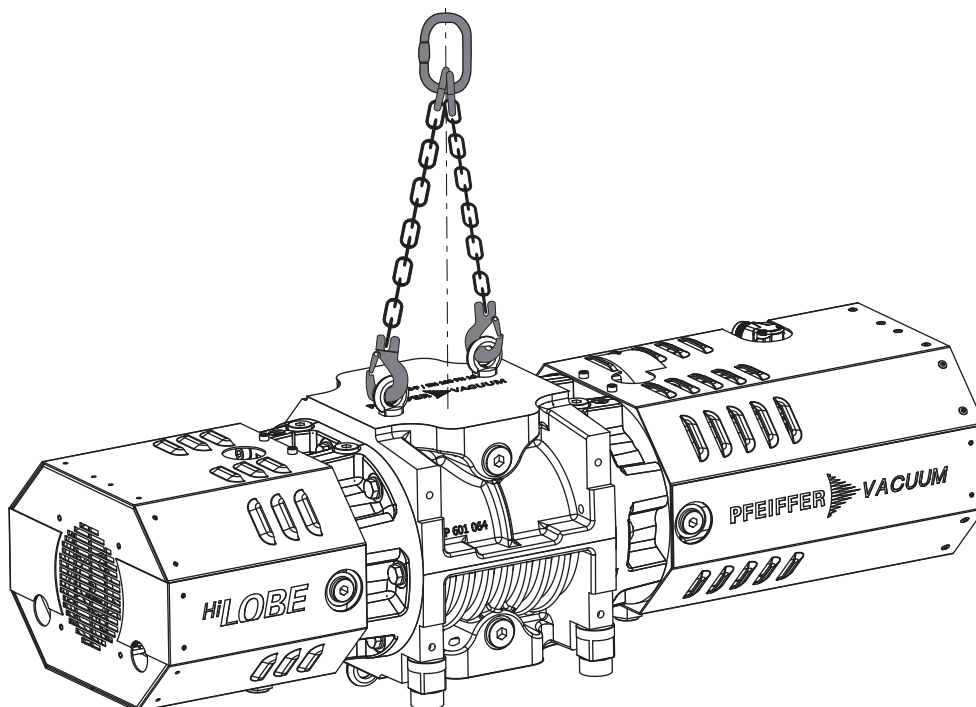

Fig. 7: Transporting the vacuum pump

Information for transport of the vacuum pump without packaging

2 eye bolts are included in the shipment, which are firmly bolted to the vacuum pump ex-factory.

1. Unpack the vacuum pump.
2. Attach suitable lifting tools to both eye bolts.
3. Pay attention to the correct use and fastening of the lifting equipment.
4. Lift the vacuum pump out of the transport packaging vertically.
5. Remove the eye bolts after transport.
6. Keep the eye bolts for future use.

4.2 Storing the vacuum pump

The roots pumps do not have **any corrosion protection** on the inside.



Pfeiffer Vacuum recommends storing the products in their original transport packaging.

Procedure

1. Close both connection flanges.
2. Check that the other openings, such as sealing gas connections or measurement connections are correctly closed.
3. Store the roots pump only in dry, dust-free rooms, within the specified ambient conditions.
 - In rooms with humid or aggressive atmospheres, seal the roots pump airtight in a plastic bag, together with a drying agent.
 - The best corrosion protection for the roots pump is achieved by evacuating and then filling the suction chamber with nitrogen.
 - Change the lubricant after a storage period of more than 2 years.
4. If you intend to store the roots pump for longer periods, we recommend that you use a special corrosion protection agreed with Pfeiffer Vacuum.



5 Installation

5.1 Installing the vacuum pump

General notes for the installation of vacuum components

- ▶ Choose an installation location that permits access to the product and to supply lines at all times.
- ▶ Observe the ambient conditions given for the area of use.
- ▶ Provide the highest possible level of cleanliness during assembly.
- ▶ Ensure that flange components during installation are grease-free, dust-free and dry.

Installation conditions

1. Check the carrying capacity of the floor at the installation location.
2. Ensure the prescribed mounting orientation of the vacuum pump before the vacuum pump is filled with lubricant for the first time.
3. Place the vacuum pump on a flat, horizontal and fixed surface, to safeguard the lubricant supply.
 - Reference surface is the vacuum flange.
4. Bolt the vacuum pump to the standing surface (4 × M8), making sure that no stress is applied to the vacuum pump.
5. Maintain the minimum distances to bordering surfaces to guarantee sufficient air circulation.
6. Leave the filling/drain holes and sight glasses freely accessible.
7. Fill with lubricant prior to first commissioning.

5.2 Mounting orientations

NOTICE

Damage to the vacuum pump due to incorrect mounting orientation

Impermissible mounting orientations will result in contamination of the process vacuum or damage to the vacuum pump.

- ▶ Operate the vacuum pump only with the prescribed mounting orientation.
 - Changing the mounting orientation is only possible via factory conversion!

The respective mounting orientation of the roots pump is defined at the factory during production:

- Vertical direction of flow (standard)
- Horizontal direction of flow (option), turned by 90°

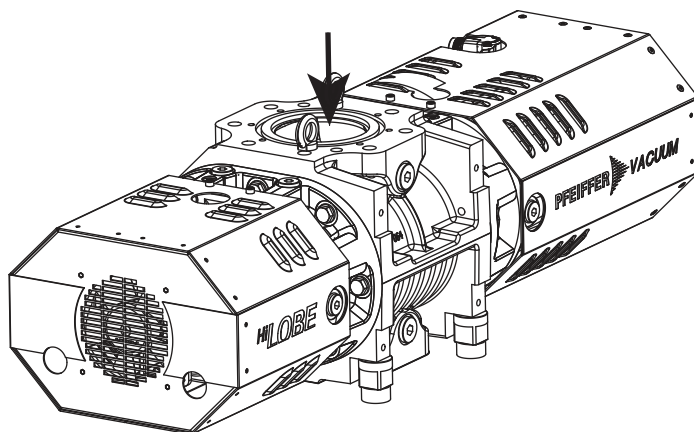

Fig. 8: Mounting orientation: Vertical direction of flow



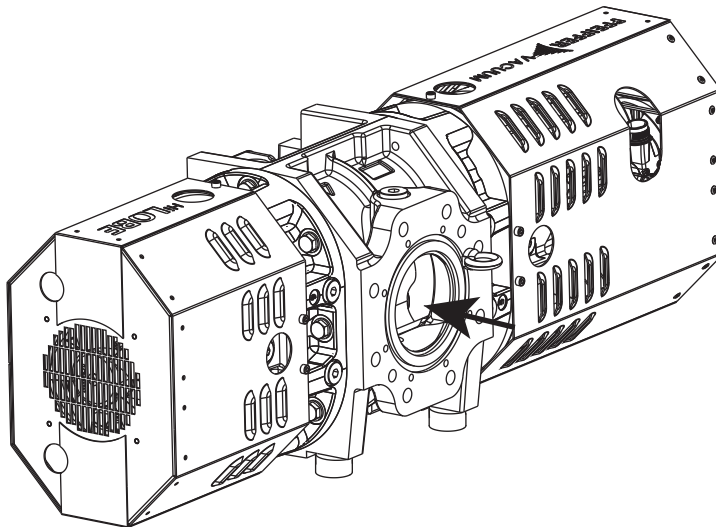

Fig. 9: Mounting orientation: Horizontal direction of flow

5.3 Filling with lubricant

NOTICE

Property damage from using non-approved lubricant

Attainment of product-specific performance data is not ensured. If non-approved lubricants are used, all liability and warranty claims against Pfeiffer Vacuum are excluded.

- ▶ Use approved lubricant only.
- ▶ Use alternative, application-specific lubricants only following consultation with Pfeiffer Vacuum.

The lubricant type is listed on the rating plate

- ▶ Please refer to rating plate of the vacuum pump for type and quantity of intended lubricant.
 - Only the lubricant used during initial installation is permissible.
- ▶ Contact Pfeiffer Vacuum if you want to use another type of lubricant.

Permissible lubricants

- P3 (standard lubricant)
- Other lubricants in preparation

Required consumables

- Lubricant of the vacuum pump

Required tools

- Allen key, **WAF 8**
- Ring spanner, **WAF 27**



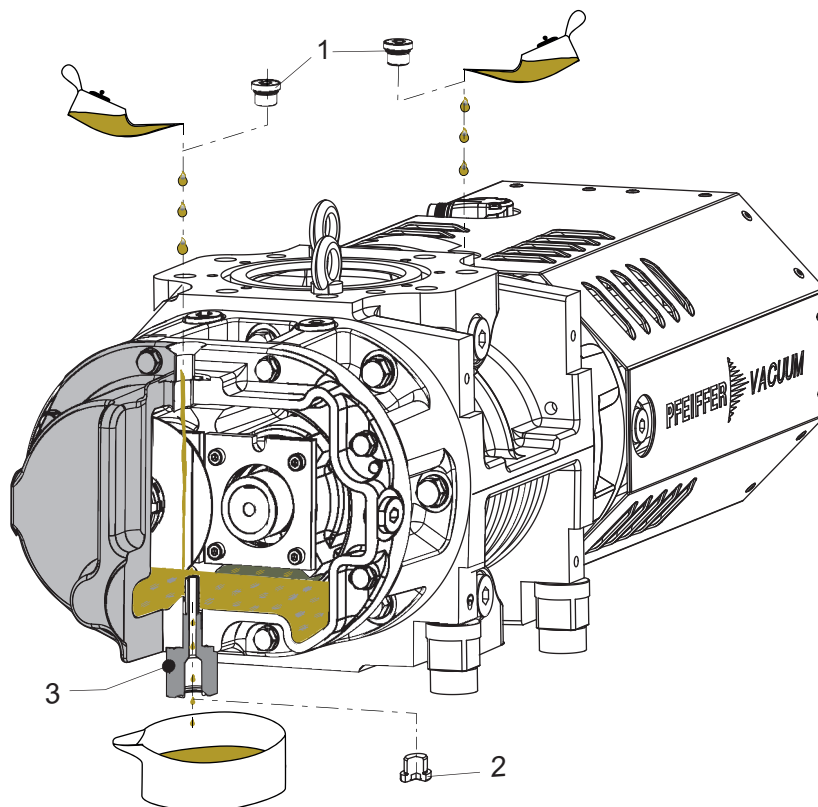

Fig. 10: Filling with lubricant

- | | |
|-----------------|----------------------|
| 1 Filler screws | 3 Fill level limiter |
| 2 Drain screw | |



Filling the lubricant

The oil chambers of the roots pump are each equipped with a fill level limiter. A riser tube limits the max. fill level.

- Filling quantity, motor side: approx. 400 ml
- Filling quantity, opposite side: approx. 250 ml

Filling with lubricant

1. Make sure that there is sufficient space underneath the pump to be able to place a collection receptacle for the lubricant.
2. Unscrew the filler screws.
3. Hold the fill level limiter with the ring spanner and unscrew the drain screw at the same time.
4. Place a collection receptacle under each drain.
5. Fill the lubricant on both sides up to the maximum fill level.
 - When completely filled, lubricant overflows at the fill level limiter and drips out of the drain opening.
6. Screw the filler and drain screws back in.

5.4 Connecting the vacuum side

⚠ WARNING

Risk of crushing from rotating parts

Fingers and hands may be caught by rotating pistons within the connection flange. This results in severe injuries.

- ▶ Keep limbs out of the reach of the roots pump.



NOTICE

Property damage from intake of solid particles

During commissioning, there is a risk of damage to the suction chamber from dirt from the system or the pipes.

- ▶ Use a suitable protective strainer ("start-up strainer") in the intake flange.
- ▶ Ensure that this strainer is only removed when the risk of solid particles entering the vacuum pump can be excluded.
 - Observe any pumping speed decrease.

Required tools

- Ring spanner, **WAF 13** with flange DN 100 ISO-F
- Ring spanner, **WAF 24** with flange DN 100 PN16

Connecting the vacuum side

1. Degrease the connection flange.
2. Clear welded lines of any tinder, loose particles etc. prior to installation.
3. Route the piping between the vacuum pump and vacuum chamber so that it remains as short as possible; at a minimum, the nominal diameter of the pump flange.
4. Select a larger nominal diameter for pipe lengths > 5 m.
5. Support or suspend the piping to the vacuum pump so that no piping system forces act on the vacuum pump.
6. Always use **all** prescribed bolts for fastening the flanges and consider the prescribed pressure stage for PN 16.

5.5 Connecting the fore-vacuum side

⚠ WARNING

Risk of crushing from rotating parts

Fingers and hands may be caught by rotating pistons within the connection flange. This results in severe injuries.

- ▶ Keep limbs out of the reach of the roots pump.

⚠ CAUTION

Danger of injury from bursting as a result of high pressure in the exhaust line

Faulty or inadequate exhaust pipes lead to dangerous situations, e.g. increased exhaust pressure. There is a danger of bursting. Injuries caused by flying fragments, the escaping of high pressure, and damage to the unit cannot be excluded.

- ▶ Route the exhaust line without shut-off units.
- ▶ Observe the permissible pressures and pressure differentials for the product.
- ▶ Check the function of the exhaust line on a regular basis.

NOTICE

Risk of damage from gas backflow into the roots pump

Due to the backflow of process gas, the electronic equipment is susceptible to irreversible damage caused by regenerative energy produced with rotation of the piston.

- ▶ Equip the vacuum pump with a facility that prevents the backflow of gases.
- ▶ Use, e.g. a shut-off facility on the fore-vacuum side and block the line directly after switching off the vacuum pump.
- ▶ As an alternative, use a backing pump with integrated vacuum safety valve.

Required tools

- Ring spanner, **WAF 13** with flange DN 100 ISO-F
- Ring spanner, **WAF 24** with flange DN 100 PN16





Condensate separator

Pfeiffer Vacuum recommends installing a condensate separator, with condensate drain at the lowest point of the exhaust line.

Connecting the fore-vacuum side

1. Choose a minimum pipe cross section equal to the nominal diameter of the pressure flange.
2. Clear welded lines of any tinder, loose particles etc. prior to installation.
3. Route the pipes so that no mechanical tension can act on the roots pump or the backing pump.
4. Install a bellows in the piping if necessary.
5. Ensure that mating flanges are in a parallel position.
6. Install the pipes downward from the vacuum pump, so that condensate does not flow back into the roots pump.

5.6 Connect the switch box

⚠ CAUTION

Electric shock and damage to the vacuum pump and electronic drive unit due to improper connection and disconnection of components

With existing power supply connection to the switch box, there is a risk of electric shock when making contact with the motor connecting plug. Even after the power supply has been switched off, the vacuum pump continues to deliver electrical energy during its run-down period. If the units are disconnected prematurely, there is the risk of electric shock, and destruction of electric components.

- ▶ Always interrupt the power supply connection at the switch box before connecting the power supply plug to the motor.
- ▶ With existing power supply connection to the switch box or when the pistons are running, never disconnect the motor connecting plug.
- ▶ After switching off, wait at least another 5 minutes until the capacitors have discharged before separating the cable connection.

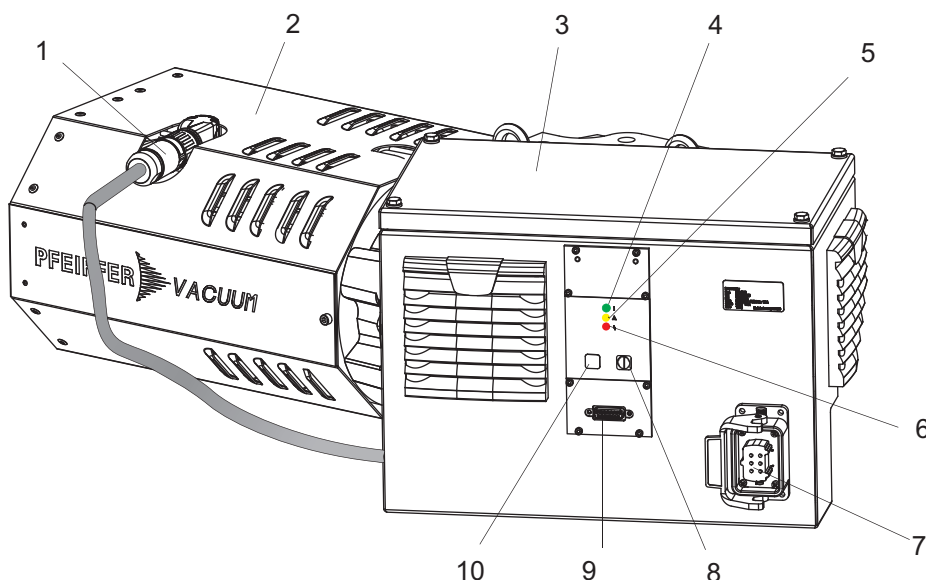

Fig. 11: Connect the switch box

- | | |
|--------------------------|----------------------|
| 1 Motor connecting cable | 6 Status LED, red |
| 2 Fan cover | 7 Mains power supply |
| 3 Switch box | 8 On/off button |
| 4 Status LED, green | 9 Interface |
| 5 Status LED, yellow | 10 Stand-by button |

Connect the motor connecting cable

1. Connect the motor connecting cable to the motor.



5.7 Connect the temperature sensors and fan

The roots pump has an M 6 connecting thread on each of its two oil chambers with pre-assembled temperature sensors for temperature monitoring. The respective cable is routed to the outside through a hole in the fan cover. The second cable is each intended for connecting to the fan.

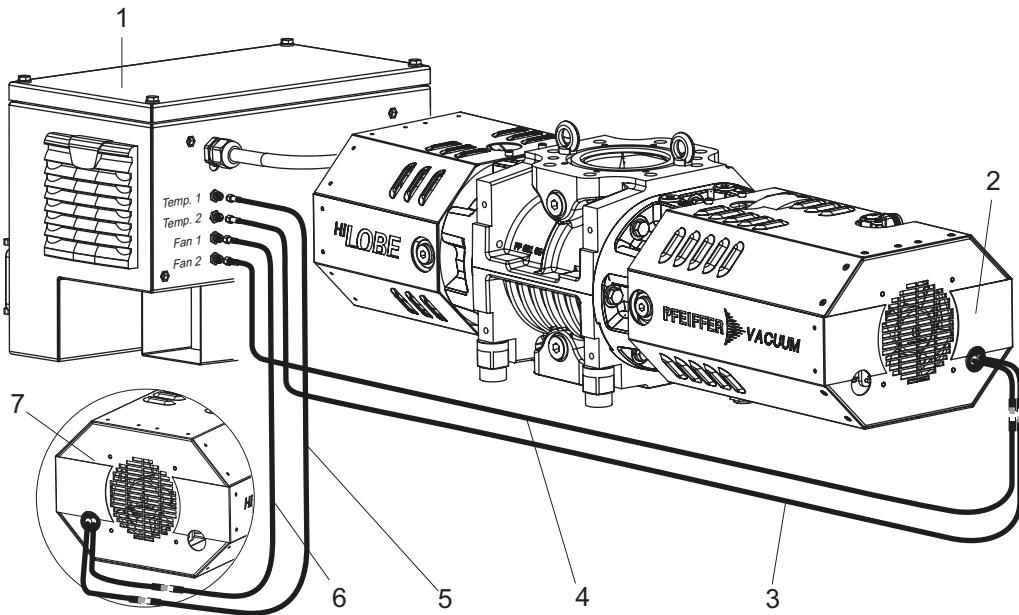

Fig. 12: Connect the extension cable

- | | |
|--|--|
| 1 Switch box | 4 Connecting cable, fan 2 |
| 2 Motor side | 5 Connecting cable, temperature sensor 1 |
| 3 Connecting cable, temperature sensor 2 | 6 Connecting cable, fan 1 |

Connect the extension cable

The sensor and fan cable are safeguarded geometrically against interchanging.

1. Connect the connecting cables of both temperature sensors to the connections (temp. 1/2) provided on the switch box.
2. Connect the connecting cables of both fans to the connections (fan 1/2) provided on the switch box.

5.8 Establishing mains connection

⚠ DANGER

Danger to life from electric shock

Contact with exposed and live elements generate an electric shock. Incorrect connection of the mains supply leads to the risk of live housing parts that can be touched. There is a risk to life.

- ▶ Before the installation, check that the connection leads are voltage-free.
- ▶ Make sure that electrical installations are only carried out by qualified electricians.
- ▶ Provide adequate grounding for the device.
- ▶ After connection work, do a PE conductor check.

⚠ WARNING

Risk of danger to life through missing mains disconnection device

The vacuum pump and electronic drive unit are **not** equipped with a mains disconnection device (mains switch).

- ▶ Install a suitable motor protection switch.
- ▶ Obtain the power details for the setting value from the motor rating plate.



⚠ WARNING

Risk of fatal injury due to electric shock on account of incorrect installation

The device's power supply uses life-threatening voltages. Unsafe or improper installation can lead to life-threatening situations from electric shocks obtained from working with or on the unit.

- ▶ Ensure safe integration into an emergency off safety circuit.
- ▶ Do not carry out your own conversions or modifications on the unit.

i

Electromagnetic compatibility

The electronic drive unit of the vacuum pump complies with the conditions of standard IEC 61000-3-12 stipulating that the permissible short-circuit capacity is observed at the supply terminal of the customer's system with the public network.

- Do not install the vacuum pump in living areas as the electronic drive unit does not provide any protection for the radio reception.
- Ensure that the vacuum pump is connected only to a supply terminal featuring a short-circuit capacity of **Ssc ≥ 351**.
- If necessary, consult the distribution network operator.

The vacuum pumps are intended for operation only with original electronic drive unit and frequency converter. The respectively valid input voltage range can be seen on the rating plate.

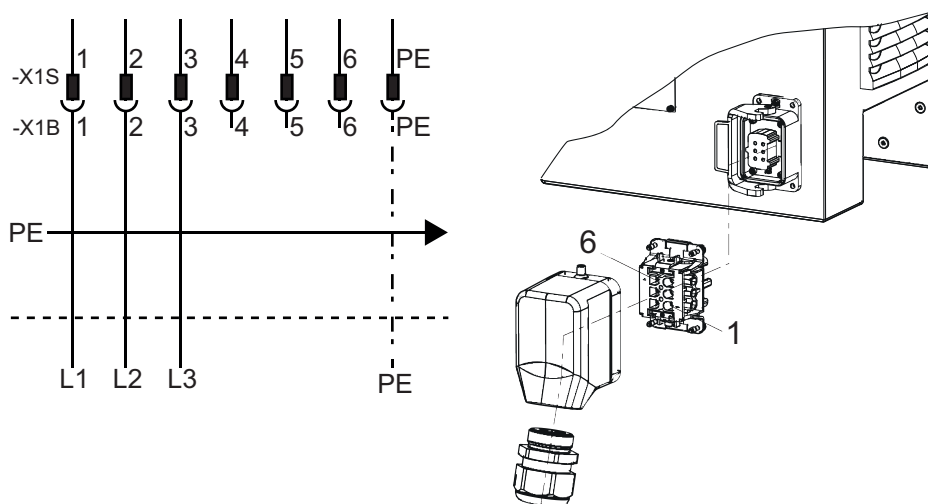

Fig. 13: Mains connection pin assignment

1	Phase L1	5	n. c.
2	Phase L2	6	n. c.
3	Phase L3	PE	Earthed conductor
4	n. c.		

Establishing mains connection

- ▶ Make sure that you have the correct supply voltage.
- ▶ Assemble your own power supply cable using the original power supply connector from the scope of delivery.

6 Interfaces

6.1 "Remote" interface

NOTICE	
Property damage on the electronics	
Separating all plug-and-socket connections within the bus system with voltage supply switched on may lead to the destruction of electronic components.	
<ul style="list-style-type: none"> ▶ Always disconnect the voltage supply before removing the connecting plug. ▶ After switching off the power supply pack, wait until the residual load has dispersed completely before disconnecting the plug-and-socket connection. 	

The 15-pin sub-D connection with the "remote" designation offers the possibility to operate the electronic drive unit via remote control. The following specifications are the factory settings for the electronic drive unit. They can be configured with the Pfeiffer Vacuum parameter set.

- ▶ Utilize the screened plug and cable.

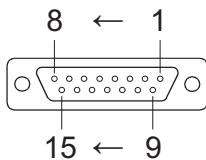

Fig. 14: Pin assignment of the D-Sub socket, 15-pin

Pin	Function	Description, factory setting
1	n.c.	
2	DI access request	V+: Control via DIs, --> GND/open: Control unlocked
3	DI1	V+: Rotation speed setting mode, --> GND/open: no rotation speed setting mode
4	n.c.	
5	DI pumping station	V+: Vacuum pump on, --> GND/open: Vacuum pump off
6	DI stand-by	V+: Stand-by, --> GND/open: no stand-by
7	+24 V DC output (V+)	Reference voltage for all digital inputs (5 W max.)
8	DO1	GND: Error, V+: no error (current max. 80 mA)
9	DO2	GND: Vacuum pump off, V+: Vacuum pump on (current max. 80 mA)
10	n.c.	
11	n.c.	
12	n.c.	
13	RS-485	D+
14	RS-485	D-
15	Ground (GND)	Ground connection of the voltage supply; reference ground for all digital inputs and outputs

Tbl. 5: Plug arrangement of the D-Sub socket, 15-pin

6.1.1 Voltage output

24 V DC output/pin 7: Inputs 2 to 6 are activated if they are connected to pin 7 (active high) with +24 VDC. They can also be activated via an external SPS. The functions are deactivated by "SPS high level" and by "SPS low level".

- PLC High level: +13 V to +33 V
- PLC Low level: -33 V to +7 V
- Ri: 7 kΩ
- I_{max} < 200 mA



6.1.2 Inputs

The digital inputs switch various electronic drive unit functions. Inputs are assigned with functions ex-factory. You can configure them via the RS-485 interface and the Pfeiffer Vacuum parameter set.

DI remote priority/pin 2

V+: The "remote" connection has control priority over all other control sources.
open: Remote priority "inactive"

DI1 (rotation speed setting mode)/pin 3

V+: Rotation speed setting mode "active"
open: Rotation speed setting mode "inactive"

DI pumping station/pin 5

V+: Vacuum pump on.
Control of all components connected and malfunction acknowledgement.
open: Vacuum pump off

DI stand-by / pin 6

V+: Stand-by activated
The stand-by rotation speed is fixed at 25 Hz.
GND/ open: Stand-by off

6.1.3 Outputs

The digital outputs have a maximum load limit of 24 V/80 mA per output. All outputs listed are configurable with the Pfeiffer Vacuum parameter set via the RS-485 interface (description relates to factory settings).

DO1/Pin 8

V+: No errors
After applying the voltage supply, the digital output DO1 permanently outputs V+ meaning which means "no error".
GND Error
"Active low" signifies "Error" (common error message).

DO2/Pin 9

V+: Vacuum pump on
"Active high" means "Vacuum pump on" and rotates at set rotation speed.
Example: use the signal for the message vacuum pump "Ready for operation".
GND: Vacuum pump off

6.1.4 RS-485

Pin 13 and pin 14

You can connect a Pfeiffer Vacuum display and control unit (DCU or HPU) or an external PC via pin 13 and pin 14 on the D-sub connection of the electronic drive unit.

6.2 Interface RS-485

DANGER

Danger to life from electric shock

When establishing the voltages that exceed the specified safety extra-low voltage (according to IEC 60449 and VDE 0100), the insulating measures will be destroyed. There is a danger to life from electric shock at the communication interfaces.

- Connect only suitable devices to the bus system.

The interface with the designation “RS-485” is intended for the connection of a Pfeiffer Vacuum display and control unit (DCU or HPU) or an external computer. The connections are galvanically safe and are isolated from the maximum supply voltage for the electronic drive unit.

Designation	Value
Serial interface	RS-485
Baudrate	9600 Baud
Data word length	8 bit
Parity	none (no parity)
Start bits	1
Stop bits	1

Tbl. 6: Features of the RS-485 interface

Connecting a Pfeiffer Vacuum display and control units or PC

- ▶ Use the connection cable from the control unit scope of delivery or from the accessories program.
- ▶ You can connect one external control unit to the RS-485 interface.
- ▶ You can connect a USB interface (PC) via the USB/RS-485 converter.

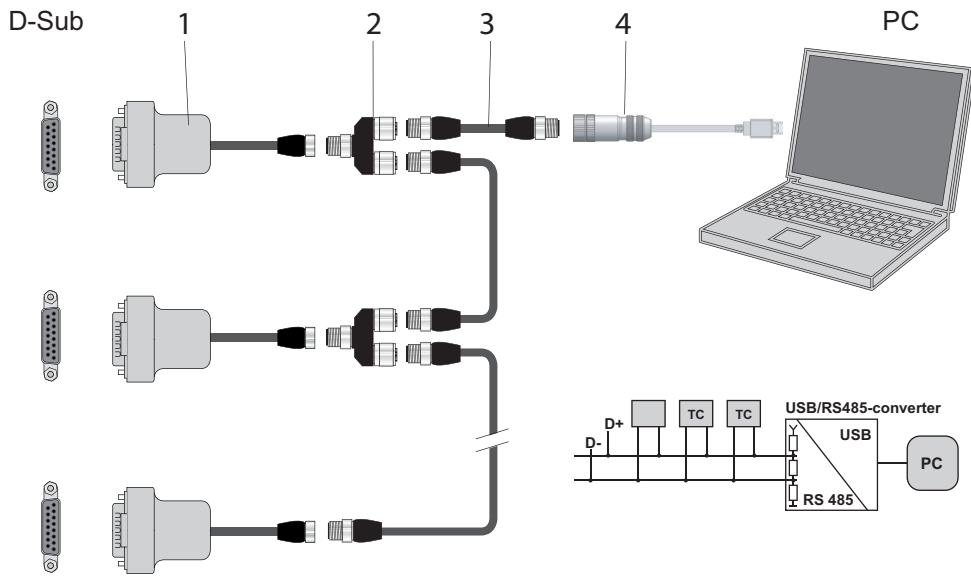

Fig. 15: Cross-link via connection RS-485 using connection cables and accessories

- 1 Connection cable with RS-485
- 2 Y-connector for RS-485
- 3 M12 to M12 extension cable
- 4 USB RS-485 converter

Networking as RS-485 bus

The group address of the electronic drive unit is 902.

1. Install the devices according to the specification for RS-485 interfaces.
2. Make sure that all devices connected to the bus have different RS-485 device addresses [P:797].
3. Connect all devices to the bus with RS-485 D+ and RS-485 D-.

6.3 Pfeiffer Vacuum protocol for RS-485 interface

6.3.1 Telegram frame

The telegram frame of the Pfeiffer Vacuum protocol contains only ASCII code characters [32; 127], the exception being the end character of the telegram C_R. Basically, a master (e.g. a PC) sends a telegram, which is answered by a slave (e.g. electronic drive unit or transmitter).

a2	a1	a0	*	0	n2	n1	n0	l1	l0	dn	...	d0	c2	c1	c0	C _R
----	----	----	---	---	----	----	----	----	----	----	-----	----	----	----	----	----------------



a2 – a0	Unit address for slave ○ <ul style="list-style-type: none"> Individual address of the unit ["001";"255"] Group address "9xx" for all identical units (no response) global address "000" for all units on the bus (no response)
*	Action according to telegram description
n2 – n0	Pfeiffer Vacuum parameter numbers
l1 – l0	Data length dn to d0
dn – d0	Data in the respective data type (see chapter "Data types", page 34).
c2 – c0	Checksum (sum of ASCII values of cells a2 to d0) modulo 256
C _R	carriage return (ASCII 13)

6.3.2 Telegram description

Data query ☞ --> ○ ?

a2	a1	a0	0	0	n2	n1	n0	0	2	=	?	c2	c1	c0	C _R
----	----	----	---	---	----	----	----	---	---	---	---	----	----	----	----------------

Control command ☞ --> ○ !

a2	a1	a0	1	0	n2	n1	n0	l1	l0	dn	...	d0	c2	c1	c0	C _R
----	----	----	---	---	----	----	----	----	----	----	-----	----	----	----	----	----------------

Data response / Control command understood ○ --> ☞

a2	a1	a0	1	0	n2	n1	n0	l1	l0	dn	...	d0	c2	c1	c0	C _R
----	----	----	---	---	----	----	----	----	----	----	-----	----	----	----	----	----------------

Error message ○ --> ☞

a2	a1	a0	1	0	n2	n1	n0	0	6	N	O	_	D	E	F	c2	c1	c0	C _R
										_	R	A	N	G	E				
										_	L	O	G	I	C				

NO_DEF Parameter number n2–n0 no longer exists
 _RANGE Data dn–d0 outside the permissible range
 _LOGIC Logical access error

6.3.3 Telegram example 1

Data query

Current rotation speed (parameter [P:309], device address slave: "123")

☞ --> ○ ?	1	2	3	0	0	3	0	9	0	2	=	?	1	1	2	C _R
ASCII	49	50	51	48	48	51	48	57	48	50	61	63	49	49	50	13

Data response: 633 Hz

Current rotation speed (parameter [P:309], device address Slave: "123")

○ --> ☞	1	2	3	1	0	3	0	9	0	6	0	0	0	6	3	3	0	3	7	C _R
ASCII	49	50	51	49	48	51	48	57	48	54	48	48	48	54	51	51	48	51	55	13

6.3.4 Telegram example 2

Control command

Switch on the pumping station (parameter [P:010], device address Slave: "042")

☞ --> ○ !	0	4	2	1	0	0	1	0	0	6	1	1	1	1	1	1	0	2	0	C _R
ASCII	48	52	50	49	48	48	49	48	48	54	49	49	49	49	49	49	48	50	48	13

Control command understood

Switch on the pumping station (parameter [P:010], device address Slave: "042")

○ --> 	0	4	2	1	0	0	1	0	0	6	1	1	1	1	1	1	0	2	0	C _R
ASCII	48	52	50	49	48	48	49	48	48	54	49	49	49	49	49	49	48	50	48	13

6.3.5 Data types

No.	Data type	Description	Length l1 – l0	Example
0	boolean_old	Logical value (false/true)	06	000000 corresponds with false 111111 corresponds with true
1	u_integer	Positive whole number	06	000000 to 999999
2	u_real	Positive fixed point number	06	001571 corresponds with 15.71
3	u_expo	Positive exponential number	06	1.2E-2 corresponds with $1,2 \cdot 10^{-2}$ 005E8 corresponds with $5 \cdot 10^8$
4	string	Any character string with 6 characters. ASCII codes between 32 and 127	06	TC_110, TM_700
6	boolean_new	Logical value (false/true)	01	0 corresponds with false 1 corresponds with true
7	u_short_int	Positive whole number	03	000 to 999
10	u_expo_new	Positive exponential number. The last of both digits are the exponent with a deduction of 20.	06	100023 corresponds with $1,0 \cdot 10^3$ 100000 corresponds with $1,0 \cdot 10^{-20}$
11	string16	Any character string with 16 characters. ASCII codes between 32 and 127	16	this-is-an-example
12	string8	Any character string with 8 characters. ASCII codes between 32 and 127	08	Example



7 Parameter set

7.1 General

Important settings and function-related characteristics are factory-programmed into the electronic drive unit as parameters. Each parameter has a three-digit number and a description. The use of the parameter is possible via Pfeiffer Vacuum displays and control panels, or externally via RS-485 using Pfeiffer Vacuum protocol.

The vacuum pump starts in standard mode with factory default pre-set parameters.



Non-volatile data storage

When switching off or in the event of unintentional voltage drop, the **parameters** and the operating hours stay saved in the electronics.



#	Three digit number of the parameter
Display	Display of parameter description
Description	Brief description of the parameters
Functions	Function description of the parameters
Data type	Type of formatting of the parameter for the use with the Pfeiffer Vacuum protocol
Access type	R (read): Read access; W (write): Write access
Unit	Physical unit of the described variable
min. / max.	Permissible limit values for the entry of a value
default	Factory default pre-setting (partially pump-specific)
	The parameter can be saved non-volatile in the electronic drive unit

Tbl. 7: Explanation and meaning of the parameters

7.2 Control commands



#	Display	Designations	Functions	Data type	Access type	Unit	min.	max.	de-fault	
002	Stand-by	Stand-by	0 = off 1 = on	0	RW		0	1	0	✓
009	ErrorAckn	Malfunction acknowledgment		0	W		1	1		
010	PumpgStatn	Pump	0 = off 1 = on	0	RW		0	1	0	✓
019	Cfg DO2	Configuration output DO2	1 = No error 2 = Error 5 = Set rotation speed reached 6 = Pump on 9 = "0" 10 = "1" 11 = Remote priority active	7	RW		0	20	6	✓
024	Cfg DO1	Configuration output DO1	Settings, see [P:019]	7	RW		0	20	1	✓
026	SpdSet-Mode	Speed actuator operation	0 = off 1 = on	7	RW		0	1	0	✓



#	Display	Designations	Functions	Data type	Access type	Unit	min.	max.	de-fault	
056	VentOnOff	Fan	0 = off 1 = on valid only for pumps with fan	0	RW		0	1	1	
060	CtrlVialnt	Operation of the interface	1 = remote 2 = RS-485 4 = PV.can 32 = Keys on the front panel 255 = Interface selection	7	RW		1	255	1	
061	IntSelLckd	Interface selection locked	0 = off 1 = on	0	RW		0	1	0	

Tbl. 8: Parameter set | Control commands



7.3 Status requests

#	Display	Designations	Functions	Data type	Access type	Unit	min.	max.	de-fault	
303	Error code	Error code		4	R					
309	ActualSpd	Actual rotational speed (Hz)		1	R	Hz				
311	OpHrsPump	Pump operating hours		1	R	h				
312	Fw version	Software version interface circuit board		4	R					
313	DrvVoltage	Supply voltage	Voltage in (V)	2	R	V				
315	Nominal Spd	Nominal rotational speed (Hz)		1	R	Hz				
316	DrvPower	Drive power	Output in (W)	1	R	W				
317	MotCurrent	Motor current		2	R	A				
324	TempPwrstg	Temperature power electronics		1	R	°C				
349	ElecName	Device name designation		4	R					
352	FWVERSDRV	Firmware of the FC		4	R					
354	HW Version	Hardware version interface circuit board		4	R					
398	ActualSpd	Actual speed (rpm)		1	R	rpm				
399	NominalSpd	Nominal rotation speed (rpm)		1	R	rpm				

Tbl. 9: Parameter set | Status requests



7.4 Set value settings

#	Display	Designations	Functions	Data type	Access type	Unit	min.	max.	default	
707	SpdSVal	Set value in rotation speed setting mode	Set rotation speed as % of nominal rotation speed	2	RW	%	25	100	75	
797	RS485Adr	RS-485 Interface address		1	RW		1	255	1	

Tbl. 10: Parameter set | Reference value inputs

7.5 Additional parameter for the DCU



Additional parameter in the control panel

The basic parameter set is set in the electronic drive unit ex-factory. For controlling connected external components (e.g. vacuum measuring instruments), additional parameters (extended parameter set) are available in the corresponding Pfeiffer Vacuum display and control panels.

- Refer to the corresponding operating instructions of the respective components.
- Select the extended parameter set with parameter **[P:794] = 1**.

#	Display	Description	Functions	Data type	Access type	Unit	min.	max.	de-fault	
340	Pressure	Actual pressure value (ActiveLine)		7	R	hPa	$1 \cdot 10^{-10}$	$1 \cdot 10^3$		
350	Ctr Name	Display and control panel: type		4	R					
351	Ctr Software	Display and control panel: software version		4	R					
738	Gauge type	Type of pressure gauge		4	RW					
794	Param set	Parameter set	0 = Basic parameter set 1 = Extended parameter set	7	RW		0	1	0	
795	Servicelin	Insert service line		7	RW				795	

Tbl. 11: Parameter for DCU functions

8 Operation

8.1 Putting the vacuum pump into operation

⚠ WARNING

Danger of poisoning due to toxic process media escaping from the exhaust pipe

During operation with no exhaust line, the vacuum pump allows exhaust gases and vapors to escape freely into the air. There is a risk of injury and fatality due to poisoning in processes with toxic process media.

- ▶ Observe the pertinent regulations for handling toxic process media.
- ▶ Safely purge toxic process media via an exhaust line.
- ▶ Use appropriate filter equipment to separate toxic process media.

Before switching on

1. Check the lubricant levels on both sight glasses.
2. Make sure that the suction chamber is free from all foreign matters;
 - Protect the vacuum pump from sucking in contaminants using suitable measures (e.g. dust filter).
3. Check the vacuum pump for visible damage and put the vacuum pump into operation only in a correct state.
4. Make sure that the shut-off units on the pressure side open before starting the pump.

8.2 Switching on the vacuum pump

The "Pumping station" parameter **[P:010]** comprises operation of the vacuum pump with control of all connected interfaces and configurations.

Procedure

After successfully completing the self-test, the electronic drive unit resets pending and corrected error messages.

You can switch on the vacuum pump in every pressure range, between atmospheric pressure and ultimate pressure.

1. Switch the voltage supply on.
2. Switch the vacuum pump on by pressing the **ⓘ** button once.
3. Allow the vacuum pump to warm up prior to process start, with the vacuum flange closed, for approx. 30 minutes.

Alternative: Switch on via the Pfeiffer Vacuum parameter

- ▶ Set the parameter **[P:010]** to the value "1".

8.3 Configuring the connections with the Pfeiffer Vacuum parameter set

The electronic drive unit is pre-configured with the factory default basic functions and is ready for operation. For individual requirements, you can configure most connections for the electronic drive unit with the parameter set.

Configure the digital outputs

- ▶ Perform the configuration as per the following table:

Option	Description
1 = No error	active, with trouble-free operation
2 = Error	active, if the error message is active
5 = Set rotation speed reached	active, once the set rotation speed is reached
6 = Pump on	active, if pump on, motor on and no error
9 = always 0	GND for the control of an external device



Option	Description
10 = always 1	V+ for the control of an external device
11 = Remote	active, if the remote priority is active

Tbl. 12: Configuration with parameters [P:019] and [P:024]

Configure the interface

- ▶ Perform the configuration as per the following table:

Option [P:060]	Description
1 = remote	Operation via connection " <i>remote</i> "
2 = RS-485	Operation via connection " <i>RS-485</i> "
4 = PV.can	For service purposes only
32 = Keys on the front panel	Manual operation
Option [P:061]	
0 = off	Interface selection can be set via [P:060].
1 = on	Interface selection locked

Tbl. 13: Configuration with parameters [P:060] and [P:061]

8.4 Operating modes

The following operating modes are possible:

- Operation without control unit
- Operation via an external control unit
- Operation via RS-485 and Pfeiffer Vacuum display and control unit or PC



Automatic start

After bypassing the contacts at pins 2, 7, 5 on the connecting plug or when using a connecting cable with respective bridges and applying the supply voltage, the vacuum pump starts up immediately.

Pfeiffer Vacuum therefore recommends switching on the voltage supply immediately before operation.

Operate without control unit

- ▶ Provide the current supply.

After applying the operating voltage, the vacuum pump carries out a self-test to check the supply voltage.

Operate via the external control

- ▶ Connect the remote control via the 15-pin D-Sub socket.

The control is carried out by means of "PLC level".

Operate with peripheral devices DCU or HPU.

1. When handling the Pfeiffer Vacuum display and control unit, observe the associated operating instructions:
 - "DCU" operating instructions available from the [Download Center](#).
 - "HPU" operating instructions available from the [Download Center](#).
2. Connect the respective peripheral device to the 15-pin D-Sub socket.
3. Make the desired settings via the RS-485 using the peripheral device.

8.4.1 Normal operation

The vacuum pump starts in normal operation with the pump-specific nominal rotation speed.

Set parameters

1. Set parameter [P:002] to "0".
2. Query the actual speed via parameter [P:398].



8.4.2 Stand-by operation

Pfeiffer Vacuum recommends stand-by operation for the vacuum pump during breaks in processes or production.

- The factory setting for stand-by is 25 Hz and cannot be changed.
- Stand-by operation has priority over rotation speed setting mode.
- When stand-by operation is active, the electronic drive unit reduces the rotation speed of the vacuum pump.

Activate stand-by rotation speed

1. Set parameter [P:002] to "1".
2. Check the actual rotational speed via parameter [P:398].

8.4.3 Operation speed setting mode



Permissible rotation speed range of the vacuum pump

Parameterization in rotation speed setting mode is subject to the permissible rotation speed range of the respective vacuum pump. The electronic drive unit regulates automatically to the next valid value.

The set rotation speed is selected via the parameter [P:707] in the range **25 to 100 %** of the set rotation speed.

The rotation speed setting mode has priority over the stand-by mode.











Set the rotation speed setting mode

1. Set the parameter [P:707] to the required value in %.
2. Set the parameter [P:026] to "1".
3. Query the set rotation speed via parameter [P:309] or [P:398].

8.5 Operation monitoring

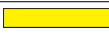
8.5.1 Operating mode display via LED

LEDs on the operator panel of the electronic drive unit indicate the respective operating status of the vacuum pump.

LED	Symbol	LED status	Display	Meaning
Green 		Off	—	without current
		On, flashing		"Pump OFF"
		On, constant		"Pump ON"
Yellow 		Off	—	no warning
		On, constant		Warning
Red 		Off	—	No errors
		On, constant		Error

Tbl. 14: Meaning of the LEDs

8.5.2 Temperature monitoring

If threshold values are exceeded, output signals from temperature sensors allow the vacuum pump to be switched to a safe state. Depending on the type, temperature thresholds for warning and malfunction messages are stored immutably in the electronic drive unit. For information purposes, various status requests are set up in the parameter set.

With an oil temperature ($T > 85\text{ °C}$), only a **"Warning"** is issued.

With impermissibly high temperature ($T > 95\text{ °C}$), the vacuum pump is switched off with an **"Error"**. After cooling down, the vacuum pump does **not** start automatically.



Acknowledge error - Query status

- ▶ Set parameter [P:010] to "0/1".

8.5.3 Checking the lubricant level**Checking the lubricant level**

1. Regularly check the lubricant level while the vacuum pump is running and at operating temperature.
2. Make sure that the level is in the area at the center of the sight glass.
3. Check the operating fluid fill level daily during continuous operation, and every time the vacuum pump is switched on.

8.6 Switching off and venting**⚠ WARNING****Risk of crushing on rotating parts when reaching into the open flange**

The pistons continue to run in the vacuum after switching off the motor, and can trap fingers and hands within their reach.

- ▶ Wait until the vacuum pump comes to a complete standstill.
- ▶ Secure the vacuum pump against re-start.

NOTICE**Risk of damage from gas backflow into the roots pump**

Due to the backflow of process gas, the electronic equipment is susceptible to irreversible damage caused by regenerative energy produced with rotation of the piston.

- ▶ Equip the vacuum pump with a facility that prevents the backflow of gases.
- ▶ Use, e.g. a shut-off facility on the fore-vacuum side and block the line directly after switching off the vacuum pump.
- ▶ As an alternative, use a backing pump with integrated vacuum safety valve.

The "Pumping station" parameter [P:010] comprises operation of the vacuum pump with control of all connected interfaces and configurations.

Procedure with clean processes

You can switch off the vacuum pump in every pressure range, between atmospheric pressure and ultimate pressure directly after the process end.

1. Close the shut-off valve in the vacuum line and disconnect the vacuum pump from the process.
2. Switch the running vacuum pump off by pressing the  button once.
3. Vent the vacuum pump via the intake side to avoid the gas backstreaming.
4. Switch off the process- and pump-specific media supply (e.g. the sealing gas supply).

Alternative: Switch off via the Pfeiffer Vacuum parameter

- ▶ Set the parameter [P:010] to the value "0".

Procedure with contaminated medium

1. Close the shut-off valve in the vacuum line and disconnect the vacuum pump from the process.
2. At the end of the process, continue to operate the vacuum pump with flushing gas supply at the vacuum flange for another approx. 20 to 40 minutes.
 - Use dry air or nitrogen.
3. Then stop the flushing gas supply.
4. Switch off the vacuum pump.
5. Vent the vacuum pump via the intake side to avoid the gas backstreaming.
6. Switch off the process- and pump-specific media supply (e.g. the sealing gas supply).

9 Maintenance

9.1 Maintenance information

⚠ WARNING

Danger to life from electric shock during maintenance and service work

There is a danger to life from electric shock when making contact with live components that still exist after the vacuum pump has been switched off.

- ▶ Disconnect the vacuum pump safely from the mains.
- ▶ Wait until the vacuum pump comes to a standstill (rotation speed =0).
- ▶ After switching off the vacuum pump, wait another 5 minutes until the capacitors have discharged.

⚠ WARNING

Risk of crushing from rotating parts

Fingers and hands may be caught by rotating pistons within the connection flange. This results in severe injuries.

- ▶ Keep limbs out of the reach of the roots pump.

NOTICE

Danger of property damage from improper maintenance

Unprofessional work on the vacuum pump will lead to damage for which Pfeiffer Vacuum accepts no liability.

- ▶ We recommend taking advantage of our service training offering.
- ▶ When ordering spare parts, specify the information on the nameplate.

Cleaning and maintenance work

- Cleaning/changing the air filter
- Cleaning the suction chamber and roots piston
- Changing the lubricant
- More in-depth work is part of the revision

Maintenance instructions

1. Switch off the vacuum pump.
2. Allow the vacuum pump to cool if needed
3. Vent the vacuum pump to atmospheric pressure via the intake side.
4. Disconnect the electronic drive unit from the mains.
5. Secure the electronic drive unit against re-start.
6. After switching off the vacuum pump, wait for at least another 5 minutes until the capacitors have discharged before starting any work.
7. Remove the vacuum pump from the system if necessary.

9.2 Checklist for inspection and maintenance

i

Notes on maintenance intervals

Depending on the process, the required maintenance intervals may be shorter than the reference values specified in the table.

- Consult with Pfeiffer Vacuum Service about shorter maintenance intervals for extreme loads or for specific processes.

You can carry out maintenance work at **Maintenance Level 1** yourself.

We recommend that Pfeiffer Vacuum Service (PV) carry out maintenance work at **Maintenance Level 3**. If the required intervals listed below are exceeded, or if maintenance work is carried out improperly



ly, no warranty or liability claims are accepted on the part of Pfeiffer Vacuum. This also applies whenever parts other than original spare parts are used.

Action	Inspection	Maintenance level 1	Maintenance level 3	Required material
described in document	BA	BA	SI	
Interval	daily	≤ 1 year	every 4 years or after 35,000 operating hours	
Inspection				
Visual and acoustic pump test	■			
<ul style="list-style-type: none"> Check the lubricant level and color of the lubricant Check the vacuum pump for leaks 				
<ul style="list-style-type: none"> Check the vacuum pump for noises (quiet running) 	■			
Maintenance level 1 – Lubricant replacement				
<ul style="list-style-type: none"> Changing the lubricant 		■		Lubricant
<ul style="list-style-type: none"> Replace the air filter (2x) on the electronic drive unit 		■		Maintenance kit 1
Maintenance level 3 – Overhaul				
<ul style="list-style-type: none"> Dismantle and clean the vacuum pump Replace the seals and all wearing parts 			■ (PV)	Maintenance kit 3
Optionally: cleaning the suction chamber				
Work on-site without removing the vacuum pump:	as required			Maintenance kit for cleaning the suction chamber
<ul style="list-style-type: none"> clean the suction chamber and piston 				

Tbl. 15: Maintenance intervals

9.3 Cleaning the air filter

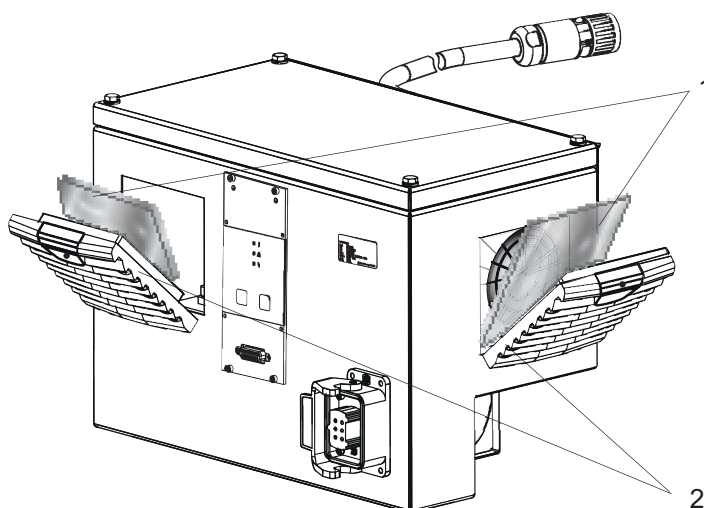

Fig. 16: Replace the baffle strainer of the fan

- 1 Baffle strainers
- 2 Louvre grille

Required tool

- Screwdriver

Clean or replace filter

1. Carefully lever off the louver grille using a screwdriver.
2. Remove the filter mats.
3. Clean or replace the filter mats.
4. Close the louver grille.

9.4 Changing the lubricant

⚠ WARNING

Health hazard and environmental damage from toxic contaminated lubricant

Toxic process media can cause lubricant contamination. When changing the lubricant, there is a health hazard due to contact with poisonous substances. Illegal disposal of toxic substances causes environmental damage.

- ▶ Wear suitable personal protective equipment when handling these media.
- ▶ Dispose of the lubricant according to locally applicable regulations.

⚠ CAUTION

Scalding from hot lubricant

Danger of scalding when draining lubricant if it comes into contact with the skin.

- ▶ Wear protective equipment.
- ▶ Use a suitable collection receptacle.



Pfeiffer Vacuum recommends determining the precise service life of the lubricant in the first operating year.

The usable life may deviate from the reference value specified depending on thermic and chemical loads, or due to penetrating process media in gear and bearing chambers.



Safety data sheets

You can obtain the safety data sheets for lubricants from Pfeiffer Vacuum on request, or from the [Pfeiffer Vacuum Download Center](#).

9.4.1 Draining the lubricant

Required tools

- Allen key, **WAF 8**
- Ring spanner, **WAF 27**



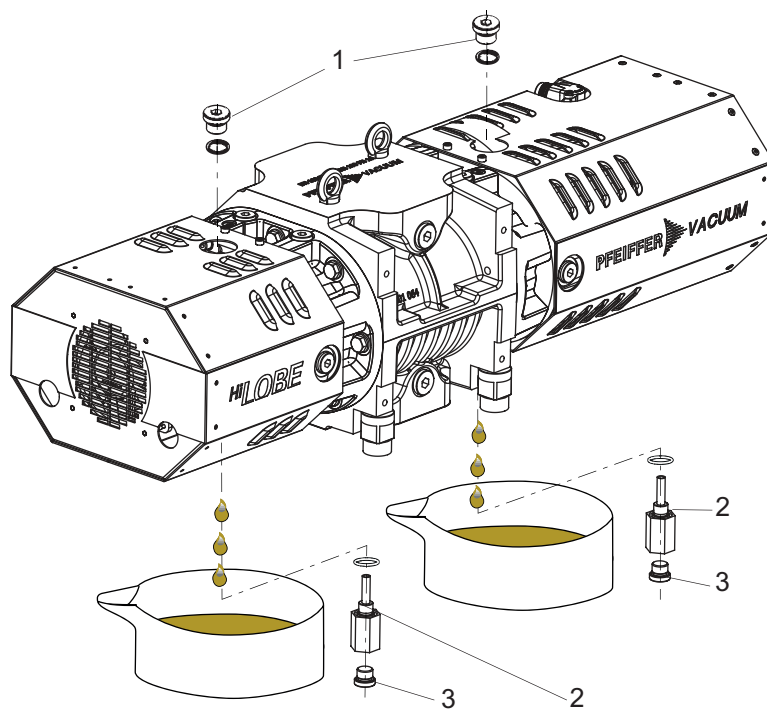

Fig. 17: Drain the lubricant

- | | |
|-------------------------------------|--------------------------|
| 1 Lubricant filler screws with seal | 3 Drain screws with seal |
| 2 Fill level limiter | |

Drain the lubricant



Unscrew the fill level limiter

To drain the lubricant, in addition to the drain screws, also unscrew the fill level limiter on the underside of the pump.

1. Make sure that there is sufficient space underneath the pump to be able to place a collection receptacle for the lubricant.
2. Unscrew the filler screws.
3. Place the collection receptacle underneath.
4. Hold the fill level limiter with the ring spanner and unscrew the drain screw at the same time.
5. Unscrew the fill level limiter and allow the lubricant to drain.

9.4.2 Filling the lubricant

Required consumables

- Lubricant of the vacuum pump

Required tools

- Allen key, **WAF 8**
- Ring spanner, **WAF 27**

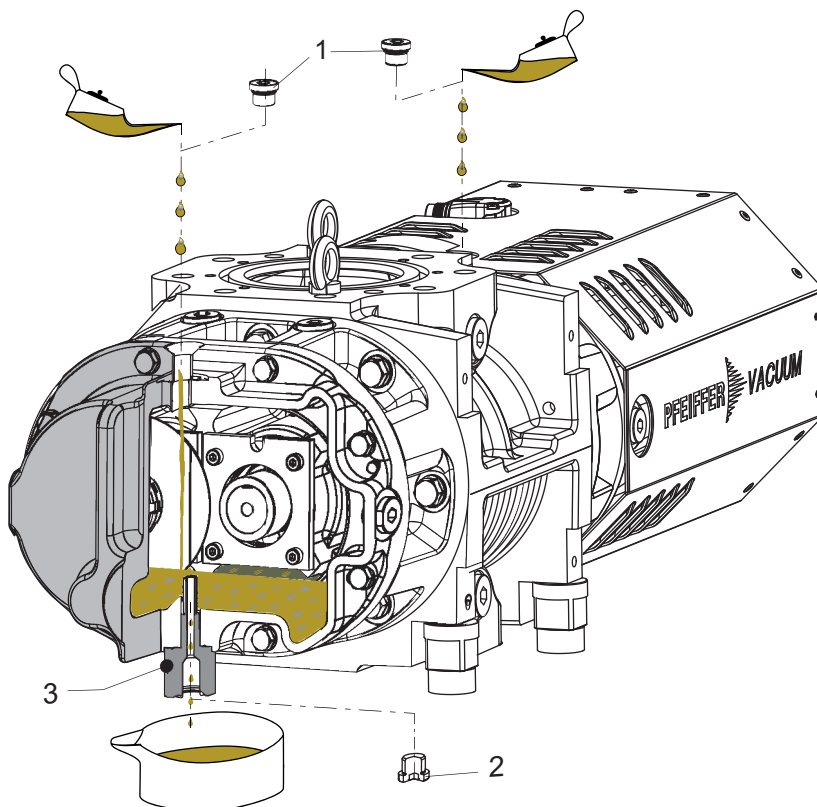

Fig. 18: Filling with lubricant

- 1 Filler screws
- 2 Drain screw
- 3 Fill level limiter

Fill lubricant

1. Screw the fill level limiter back in.
2. Place a collection receptacle under each drain.
3. Fill the lubricant on both sides up to the maximum fill level.
 - Once full, lubricant overfills the fill level limiter, and drips out of the drain hole.
4. Screw the filler and drain screws back in.



10 Decommissioning

10.1 Shutting down for longer periods

Before shutting down the vacuum pump, observe the following instructions to adequately protect the interior of the vacuum pump (suction chamber) from corrosion:

Procedure for a longer downtime of the vacuum pump (> 1 year)

1. Allow the vacuum pump to cool down.
2. Clean suction chamber.
3. Change the lubricant.
4. Seal the vacuum flange and fore-vacuum flange and any other openings with screw caps.
5. Evacuate the pump interior via the measurement connection on the vacuum side, to $p < 1$ hPa.
6. Vent the suction chamber of the vacuum pump through the measurement connection using dry air or nitrogen.
7. Store the vacuum pump in dry, dust-free rooms, within the specified ambient conditions.
8. In rooms with humid or aggressive atmospheres: Hermetically seal the vacuum pump together with a drying agent in a plastic bag.
9. For storage durations of more than 2 years, we recommend you carry out maintenance and a lubricant change prior to recommissioning.
10. Please note, the vacuum pump may not be stored in the vicinity of machines, traffic routes, etc., as strong vibrations may damage the bearing.

10.2 Recommissioning

NOTICE

Damage to the roots pump due to aging of the lubricant

The useful life of the lubricant is limited (max. 2 years). Prior to recommissioning, carry out the following operations following inactivity of **2 years or more**:

- ▶ Observe the maintenance instructions – consult Pfeiffer Vacuum where necessary.
- ▶ Change the lubricant.
- ▶ Check the bearing and replace any worn elastomer parts.

Procedure when recommissioning the vacuum pump

1. Check the roots pump for visible damage and operate the roots pump only in an appropriate operating status.
2. Check the interior of the pump for contaminants.
3. Remove any drying pearls from the suction chamber.
4. Do not operate the vacuum pump and notify [Pfeiffer Vacuum Service](#) in the event of housing parts exhibiting signs of rust.
5. Perform a leak test prior to recommissioning the vacuum pump as required.

10.3 Disposing of the vacuum pump

⚠ WARNING

Health hazard through poisoning from toxic contaminated components or devices

Toxic process media result in contamination of devices or parts of them. During maintenance work, there is a risk to health from contact with these poisonous substances. Illegal disposal of toxic substances causes environmental damage.

- ▶ Take suitable safety precautions and prevent health hazards or environmental pollution by toxic process media.
- ▶ Decontaminate affected parts before carrying out maintenance work.
- ▶ Wear protective equipment.

Procedure

- ▶ Dispose safely of all substances according to local regulations.

11 Malfunctions

11.1 General

WARNING

Danger to life from electric shock in the event of a fault

In the event of a fault, devices connected to the mains may be live. There is a danger to life from electric shock when making contact with live components.

- ▶ Always keep the mains connection freely accessible so you can disconnect it at any time.

CAUTION

Danger of burns on hot surfaces

In the event of a fault, the surface temperature of the vacuum pump can increase to above 105 °C.

- ▶ Allow the vacuum pump to cool down before carrying out any work.
- ▶ Wear personal protective equipment if necessary.



No automatic restart following a power failure or error state

After restoring the power supply, the vacuum pump remains in the "Switched Off" state.

- Switch the vacuum pump on actively.

Vacuum pump and electronic drive unit malfunctions always result in a warning or error message. In both cases, you will receive an error code that you can read out via the interfaces of the electronic drive unit. Generally, the LEDs on the control panel display the operating messages. If an error occurs, switch off the vacuum pump and connected devices.

11.2 Troubleshooting

Should malfunctions occur, you can find information about potential causes and how to fix them here:

Problem	Possible causes	Remedy
The vacuum pump does not start up, no LED lights up on the operator panel of the electronic drive unit	<ul style="list-style-type: none"> • No mains voltage or operating voltage incorrect 	<ul style="list-style-type: none"> • Check the mains voltage. • Check the mains fuse.
	<ul style="list-style-type: none"> • Electronic drive unit defective 	<ul style="list-style-type: none"> • Contact Pfeiffer Vacuum Service.
	<ul style="list-style-type: none"> • Suction chamber dirty 	<ul style="list-style-type: none"> • Switch off the vacuum pump immediately. • Clean suction chamber. • If necessary, contact Pfeiffer Vacuum Service.
Vacuum pump switches off after a while after being started	<ul style="list-style-type: none"> • Thermal protection switch of the motor or the vacuum pump has triggered 	<ul style="list-style-type: none"> • Determine the cause and eliminate the fault. • Allow the vacuum pump or the motor to cool as necessary.
Vacuum pump/pumping station does not reach ultimate pressure	<ul style="list-style-type: none"> • Backing pump faulty 	<ul style="list-style-type: none"> • Check the backing pump.
	<ul style="list-style-type: none"> • Leak in system 	<ul style="list-style-type: none"> • Examine the system for leaks and, if necessary, carry out a leak test. • Eliminate leaks.
Unusual noises during operation	<ul style="list-style-type: none"> • Suction chamber dirty 	<ul style="list-style-type: none"> • Switch off the vacuum pump immediately. • Clean suction chamber.
	<ul style="list-style-type: none"> • Damage to the bearing or gear wheels 	<ul style="list-style-type: none"> • Switch off the vacuum pump immediately. • Contact Pfeiffer Vacuum Service.

Tbl. 16: Troubleshooting



11.3 Error codes

Errors (** Error E—— **) always cause the connected peripheral devices to be switched off.

Warnings (* Warning F —— *) are only displayed and do not cause components to be switched off.

Handling malfunction messages

1. Read out the error codes via the display and control panel or the PC.
2. Remove the cause of the malfunction.
3. Reset the error message with parameter **[P:009]** or by pressing the button  on the DCU.

Error code	Problem	Possible causes	Remedy
Err001	Excess rotation speed	<ul style="list-style-type: none"> • Error in the frequency converter (FC) 	<ul style="list-style-type: none"> • Contact Pfeiffer Vacuum Service.
Err002	Motor excess voltage	<ul style="list-style-type: none"> • Error in the frequency converter (FC) 	<ul style="list-style-type: none"> • Contact Pfeiffer Vacuum Service.
Err023	Motor undervoltage	<ul style="list-style-type: none"> • Error in the frequency converter (FC) 	<ul style="list-style-type: none"> • Check the mains input voltage • Contact Pfeiffer Vacuum Service.
Err042	Checksum errors	<ul style="list-style-type: none"> • Inconsistent software 	<ul style="list-style-type: none"> • Contact Pfeiffer Vacuum Service.
Err045	Excess temperature, motor	<ul style="list-style-type: none"> • Insufficient cooling 	<ul style="list-style-type: none"> • Check the cooling
Err091	Hardware error	<ul style="list-style-type: none"> • Hardware not detected 	<ul style="list-style-type: none"> • Contact Pfeiffer Vacuum Service.
Err098	Internal communication error	–	<ul style="list-style-type: none"> • Contact Pfeiffer Vacuum Service.
Err115	Invalid pump temperature signal	<ul style="list-style-type: none"> • Oil temperature sensor defective 	<ul style="list-style-type: none"> • Check the sensor and sensor cable • Replace the sensor and cable, if required
Err117	Vacuum pump excess temperature (FC)	<ul style="list-style-type: none"> • Insufficient cooling 	<ul style="list-style-type: none"> • Improve the cooling • Check the operating conditions
Err118	Overtemperature of the cooling element	<ul style="list-style-type: none"> • Insufficient cooling, • Ambient temperature too high 	<ul style="list-style-type: none"> • Improve the cooling • Check the operating conditions
Err173	Motor excess current (FC)	<ul style="list-style-type: none"> • Acceleration ramp too short • Suction chamber dirty • Short-circuit 	<ul style="list-style-type: none"> • Check the vacuum pump • Contact Pfeiffer Vacuum Service.
Err177	Overload (FC)	<ul style="list-style-type: none"> • Suction chamber contaminated - Vacuum pump clogged over a longer period • Short-circuit 	<ul style="list-style-type: none"> • Check the vacuum pump • Contact Pfeiffer Vacuum Service.

Tbl. 17: Error messages of the electronic drive unit

Error code	Problem	Possible causes	Remedy
Wrm117	Pre-alarm: Vacuum pump excess temperature (FC)	<ul style="list-style-type: none"> • Insufficient cooling 	<ul style="list-style-type: none"> • Improve the cooling • Check the operating conditions

Tbl. 18: Warning messages of the electronic drive unit

11.4 Warning and error messages when operating with DCU

Besides the device-specific warning and error messages on the electronic drive unit, additional messages are displayed with the connected display and control panel.

Display in DCU	Problem	Possible causes	Remedy
* Warning F110 *	Pressure gauge	<ul style="list-style-type: none"> • Pressure gauge faulty • Connection to the pressure gauge disconnected during operation 	<ul style="list-style-type: none"> • Check the cable connection • Carry out a restart with pressure gauge connected • Replace the pressure gauge completely
** Error E040 **	Hardware error	<ul style="list-style-type: none"> • external RAM faulty 	<ul style="list-style-type: none"> • Contact Pfeiffer Vacuum Service.
** Error E042 **	Hardware error	<ul style="list-style-type: none"> • EPROM checksum incorrect 	<ul style="list-style-type: none"> • Contact Pfeiffer Vacuum Service.



Malfunctions

Display in DCU	Problem	Possible causes	Remedy
** Error E043 **	Hardware error	<ul style="list-style-type: none"> E²PROM write error 	<ul style="list-style-type: none"> Contact Pfeiffer Vacuum Service.
** Error E090 **	Internal device error	<ul style="list-style-type: none"> RAM not large enough DCU is connected to incorrect electronic drive unit 	<ul style="list-style-type: none"> Contact Pfeiffer Vacuum Service. Connect the DCU to the correct electronic drive unit
** Error E698 **	Communication error	<ul style="list-style-type: none"> Electronic drive unit is not responding 	<ul style="list-style-type: none"> Contact Pfeiffer Vacuum Service.

Tbl. 19: Warning and error messages when using a DCU



12 Service solutions from Pfeiffer Vacuum

We offer first class service

Long vacuum component service life, coupled with low downtimes, are clear expectations that you have of us. We satisfy your needs with capable products and outstanding service.

We are consistently striving to perfect our core competence, service for vacuum components. And our service is far from over once you've purchased a product from Pfeiffer Vacuum. It often enough really just begins then. In proven Pfeiffer Vacuum quality, of course.

Our professional sales engineers and service technicians stand ready to provide hands-on support to you worldwide. Pfeiffer Vacuum offers a complete portfolio of service offerings, ranging from genuine spare parts right through to service agreements.

Take advantage of Pfeiffer Vacuum Service

Whether for preventative on-site service from our field service, fast replacement with as-new replacement products or repair in a Service Center close to you; you have various options for upholding your equipment availability. Detailed information and addresses can be found on our website in the Pfeiffer Vacuum Service section.

Advice on the optimum solution is available from your Pfeiffer Vacuum contact partner.

For quick and smooth handling of the service process, we recommend the following steps:

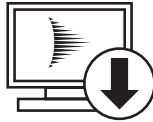

1. Download the current form templates.
 - [Declaration of Service Request](#)
 - [Service Request](#)
 - [Declaration of Contamination](#)



- a) Dismantle all accessories and keep them (all external mounted parts as valve, inlet screen, etc.).
 - b) Drain the operating fluid/lubricant as necessary.
 - c) Drain the cooling medium as necessary.
2. Fill out the service request and the declaration of contamination.

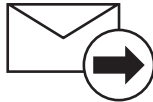

3. Send the forms via email, fax or post to your local Service Center.

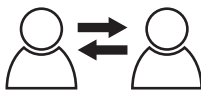

4. You will receive a response from Pfeiffer Vacuum.

PFEIFFER VACUUM

Sending of contaminated products

No units will be accepted if they are contaminated with micro-biological, explosive or radioactive substances. If products are contaminated or if the declaration of contamination is missing, Pfeiffer Vacuum will contact the customer before starting maintenance. In addition, depending on the product and the level of contamination **additional decontamination costs** may be required.



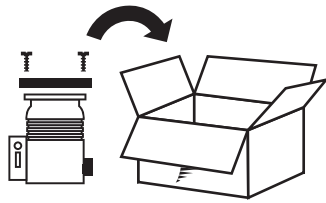

5. Prepare the product for transport in accordance with the details in the declaration of contamination.
 - a) Neutralize the product with nitrogen or dry air.
 - b) Close all openings with airtight blank flanges.
 - c) Seal the product in appropriate protective film.
 - d) Only pack the product in suitable, stable transport containers.
 - e) Observe the applicable transport conditions.

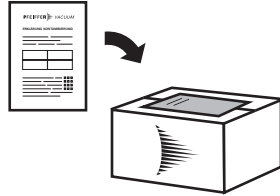

6. Affix the declaration of contamination to the **outside** of the packaging.

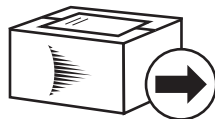

7. Then send your product to your local Service Center.

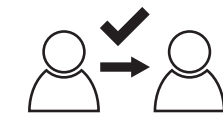

8. You will receive a confirmation message/a quotation from Pfeiffer Vacuum.

PFEIFFER VACUUM

For all service orders, our General Terms and Conditions of Sales and Supply and General Terms and Conditions of Repair and Maintenance apply to vacuum equipment and components.



13 Ordering spare parts packs

Observe the following instructions when ordering spare parts:

Procedure

- ▶ Have the vacuum pump part number, and any other necessary details from the rating plate, to hand when ordering spare parts.
- ▶ Use only original spare parts.

Spare parts packs	Pump version	Order no.
Maintenance kit 1	HiLobe 1004 HiLobe 1004 H HiLobe 1304 HiLobe 1304 H HiLobe 2104 HiLobe 2104 H	PP E47 000 -T
Maintenance kit 3	HiLobe 1004 HiLobe 1004 H HiLobe 1304 HiLobe 1304 H HiLobe 2104 HiLobe 2104 H	PP E42 000 -T
Maintenance kit for cleaning the suction chamber	HiLobe 1004 HiLobe 1004 H HiLobe 1304 HiLobe 1304 H HiLobe 2104 HiLobe 2104 H	PP E48 000 -T

Tbl. 20: HiLobe spare parts packs



14 Accessories



View the line of accessories for Pfeiffer Vacuum roots pumps online at pfeiffer-vacuum.de.

14.1 Accessory information

Fixing materials

Type-specific assembled packages ensure secure fastening of the vacuum pump. Optionally with splinter shield or protective screen.

Display units and cable

Display and operating units are used to check and adjust operating parameters. Mains, interface, connection, and extension cables provide a secure and suitable connection. Different lengths on request.

Process accessories

Gearbox evacuation, sealing gas set, spraying equipment and temperature sensors permit process-specific adaptations.

14.2 Ordering accessories

Article	Order number
Set of screws, galvanized steel, DN 100 ISO-F	PP 042 645 -T
Set of screws, stainless steel, DN 100 ISO-F	PP 042 655 -T
Set of screws, galvanized steel, DN 100 PN16	PP 042 663 -T
Bracket set, stainless steel, DN 100 ISO-K	PP 042 660 -T
Bracket set, galvanized steel, DN 100 ISO-K	PP 042 661 -T
Bracket set, galvanized steel, DN 100 ISO-K, for flange with sealing groove	PP 042 662 -T
Splinter shield, DN 100 ISO	PP 030 149 AX
Splinter shield, DN 100 PN16	PP 042 350 -X
Set of seals, FPM, DN 100 PN16	PP 042 667 -T
Centering ring with outer ring, aluminum/FPM, DN 100 ISO	PF 303 110 -T
Collar flange, stainless steel, DN 100 ISO-F	320FLU100
Collar flange, nickel-plated steel, DN 100 ISO-F	350FLU100
Set of blank flanges, stainless steel, DN 100 ISO-F	PP 042 664 -T
Set of blank flanges, stainless steel, DN 100 ISO-K	PP 042 665 -T
Set of blank flanges, stainless steel, DN 100 PN16	PP 042 666 -T
Setting Elements for Foot Mounting	PP 041 454 -T
HPU 001, Handheld Programming Unit	PM 051 510 -T
RJ 45 Interface Cable on M12	PM 051 726 -T
Accessories Package for HPU	PM 061 005 -T
USB Converter to RS-485 Interface	PM 061 207 -T
DCU 002, Display Control Unit	PM 061 348 AT
TCS 11, Adapter for TC 110/120	PM 061 636 -U
Temperature sensor, PT100, stainless steel, FPM seal	PP 100 090 -T
Extension cables (motor and temperature sensor cables), 3 m	PP 100 304 -T
Extension cables (motor and temperature sensor cables), 5 m	PP 100 306 -T
Extension cables (motor and temperature sensor cables), 10 m	PP 100 311 -T
Sealing gas device	PP 100 091 -T
Gear space extraction	PP 100 092 -T
Spray unit	PP 042 765 -U

Tbl. 21: Accessories



Article	Order number
P3, mineral oil, 0.5 l	PK 001 136 -T
P3, mineral oil, 1 l	PK 001 106 -T
P3, mineral oil, 5 l	PK 001 107 -T
P3, mineral oil, 20 l	PK 001 108 -T

Tbl. 22: Consumables

15 Technical data and dimensions

15.1 General

Basis for the technical data of Pfeiffer Vacuum roots pumps

- Specifications according to PNEUROP committee PN5
- ISO 21360-1: 2016 "Vacuum technology - Standard methods for measuring vacuum-pump performance - General description"
- Leak test to ascertain the integral leakage rate according to EN 1779: 1999 technique A1; with 100 % helium concentration, 10 s measurement duration
- Sound pressure level: distance to vacuum pump 1 m

	mbar	bar	Pa	hPa	kPa	Torr mm Hg
mbar	1	$1 \cdot 10^{-3}$	100	1	0.1	0.75
bar	1000	1	$1 \cdot 10^5$	1000	100	750
Pa	0.01	$1 \cdot 10^{-5}$	1	0.01	$1 \cdot 10^{-3}$	$7.5 \cdot 10^{-3}$
hPa	1	$1 \cdot 10^{-3}$	100	1	0.1	0.75
kPa	10	0.01	1000	10	1	7.5
Torr mm Hg	1.33	$1.33 \cdot 10^{-3}$	133.32	1.33	0.133	1

$$1 \text{ Pa} = 1 \text{ N/m}^2$$

Tbl. 23: Conversion table: Pressure units

	mbar l/s	Pa m ³ /s	sccm	Torr l/s	atm cm ³ /s
mbar l/s	1	0.1	59.2	0.75	0.987
Pa m ³ /s	10	1	592	7.5	9.87
sccm	$1.69 \cdot 10^{-2}$	$1.69 \cdot 10^{-3}$	1	$1.27 \cdot 10^{-2}$	$1.67 \cdot 10^{-2}$
Torr l/s	1.33	0.133	78.9	1	1.32
atm cm ³ /s	1.01	0.101	59.8	0.76	1

Tbl. 24: Conversion table: Units for gas throughput

15.2 Substances in contact with the media

Pump parts	Substances in contact with the media
Pump housing	Cast iron (spheroidal graphite cast iron)
Rotor	Cast iron (spheroidal graphite cast iron)
Seals	FKM

Tbl. 25: Materials that make contact with the process media

15.3 Technical data

Classification	HiLobe 1004	HiLobe 1304	HiLobe 2104
Order number	PP V20 400	PP V21 400	PP V22 400
Flange (in)	DN 100 ISO-F DN 100 PN 16	DN 100 ISO-F DN 100 PN 16	DN 100 ISO-F DN 100 PN 16
Flange (out)	DN 100 ISO-F DN 100 PN 16	DN 100 ISO-F DN 100 PN 16	DN 100 ISO-F DN 100 PN 16
Mounting orientation	Vertical	Vertical	Vertical
Electronic drive unit	RC 4000	RC 4000	RC 4000
Nominal pumping speed	520 – 1 050 m ³ /h	520 – 1 300 m ³ /h	520 – 2 100 m ³ /h



Classification	HiLobe 1004	HiLobe 1304	HiLobe 2104
Pumping speed	450 – 820 m ³ /h	450 – 990 m ³ /h	450 – 1 450 m ³ /h
max. permissible pressure differential at max. rotation speed	52 hPa	35 hPa	12 hPa
max. permissible pressure differential at min. rotation speed	75 hPa	75 hPa	75 hPa
Emission sound pressure level (EN ISO 2151) at intake pressure 1 hPa	67 dB(A)	68 dB(A)	69 dB(A)
Sealing gas	Yes	Yes	Yes
Cooling method, standard	Air, forced convection	Air, forced convection	Air, forced convection
Rotation speed	3 000 – 6 000 rpm	3 000 – 7 500 rpm	3 000 – 12 000 rpm
Protection category	IP54	IP54	IP54
Integral leak rate	< 1 · 10 ⁻⁵ hPa·l/s	< 1 · 10 ⁻⁵ hPa·l/s	< 1 · 10 ⁻⁵ hPa·l/s
Input voltage(s)	305 – 528 V AC, 50/60 Hz	305 – 528 V AC, 50/60 Hz	305 – 528 V AC, 50/60 Hz
Rated power at max. rotational speed	2 kW	2.5 kW	3.5 kW
Rotation speed at stand-by	1 500 rpm	1 500 rpm	1 500 rpm
Motor protection	PTC	PTC	PTC
Operating fluid	P3, mineral oil	P3, mineral oil	P3, mineral oil
Operating fluid filling	0.65 l	0.65 l	0.65 l
I/O interfaces	RS-485, PV.can	RS-485, PV.can	RS-485, PV.can
Ambient temperature	5 – 40 °C	5 – 40 °C	5 – 40 °C
Transport and storage temperature	-10 – 40 °C	-10 – 40 °C	-10 – 40 °C
Paint finish color	RAL 7035	RAL 7035	RAL 7035
Weight	115 kg	115 kg	115 kg

Tbl. 26: Technical data HiLobe | vertical direction of flow

Classification	HiLobe 1004 H	HiLobe 1304 H	HiLobe 2104 H
Order number	PP V30 400	PP V31 400	PP V32 400
Flange (in)	DN 100 ISO-F DN 100 PN 16	DN 100 ISO-F DN 100 PN 16	DN 100 ISO-F DN 100 PN 16
Flange (out)	DN 100 ISO-F DN 100 PN 16	DN 100 ISO-F DN 100 PN 16	DN 100 ISO-F DN 100 PN 16
Mounting orientation	Horizontal, inlet on the side	Horizontal, inlet on the side	Horizontal, inlet on the side
Electronic drive unit	RC 4000	RC 4000	RC 4000
Nominal pumping speed	520 – 1 050 m ³ /h	520 – 1 300 m ³ /h	520 – 2 100 m ³ /h
Pumping speed	450 – 820 m ³ /h	450 – 990 m ³ /h	450 – 1 450 m ³ /h
max. permissible pressure differential at max. rotation speed	52 hPa	35 hPa	12 hPa
max. permissible pressure differential at min. rotation speed	75 hPa	75 hPa	75 hPa
Emission sound pressure level (EN ISO 2151) at intake pressure 1 hPa	67 dB(A)	68 dB(A)	69 dB(A)
Sealing gas	Yes	Yes	Yes
Cooling method, standard	Air, forced convection	Air, forced convection	Air, forced convection
Rotation speed	3 000 – 6 000 rpm	3 000 – 7 500 rpm	3 000 – 12 000 rpm



Classification	HiLobe 1004 H	HiLobe 1304 H	HiLobe 2104 H
Protection category	IP54	IP54	IP54
Integral leak rate	$< 1 \cdot 10^{-5}$ hPa·l/s	$< 1 \cdot 10^{-5}$ hPa·l/s	$< 1 \cdot 10^{-5}$ hPa·l/s
Input voltage(s)	305 – 528 V AC, 50/60 Hz	305 – 528 V AC, 50/60 Hz	305 – 528 V AC, 50/60 Hz
Rated power at max. rotational speed	2 kW	2.5 kW	3.5 kW
Rotation speed at stand-by	1 500 rpm	1 500 rpm	1 500 rpm
Motor protection	PTC	PTC	PTC
Operating fluid	P3, mineral oil	P3, mineral oil	P3, mineral oil
Operating fluid filling	0.65 l	0.65 l	0.65 l
I/O interfaces	RS-485, PV.can	RS-485, PV.can	RS-485, PV.can
Ambient temperature	5 – 40 °C	5 – 40 °C	5 – 40 °C
Transport and storage temperature	-10 – 40 °C	-10 – 40 °C	-10 – 40 °C
Paint finish color	RAL 7035	RAL 7035	RAL 7035
Weight	115 kg	115 kg	115 kg

Tbl. 27: Technical data HiLobe | horizontal direction of flow

15.4 Dimensions

Dimensions in mm



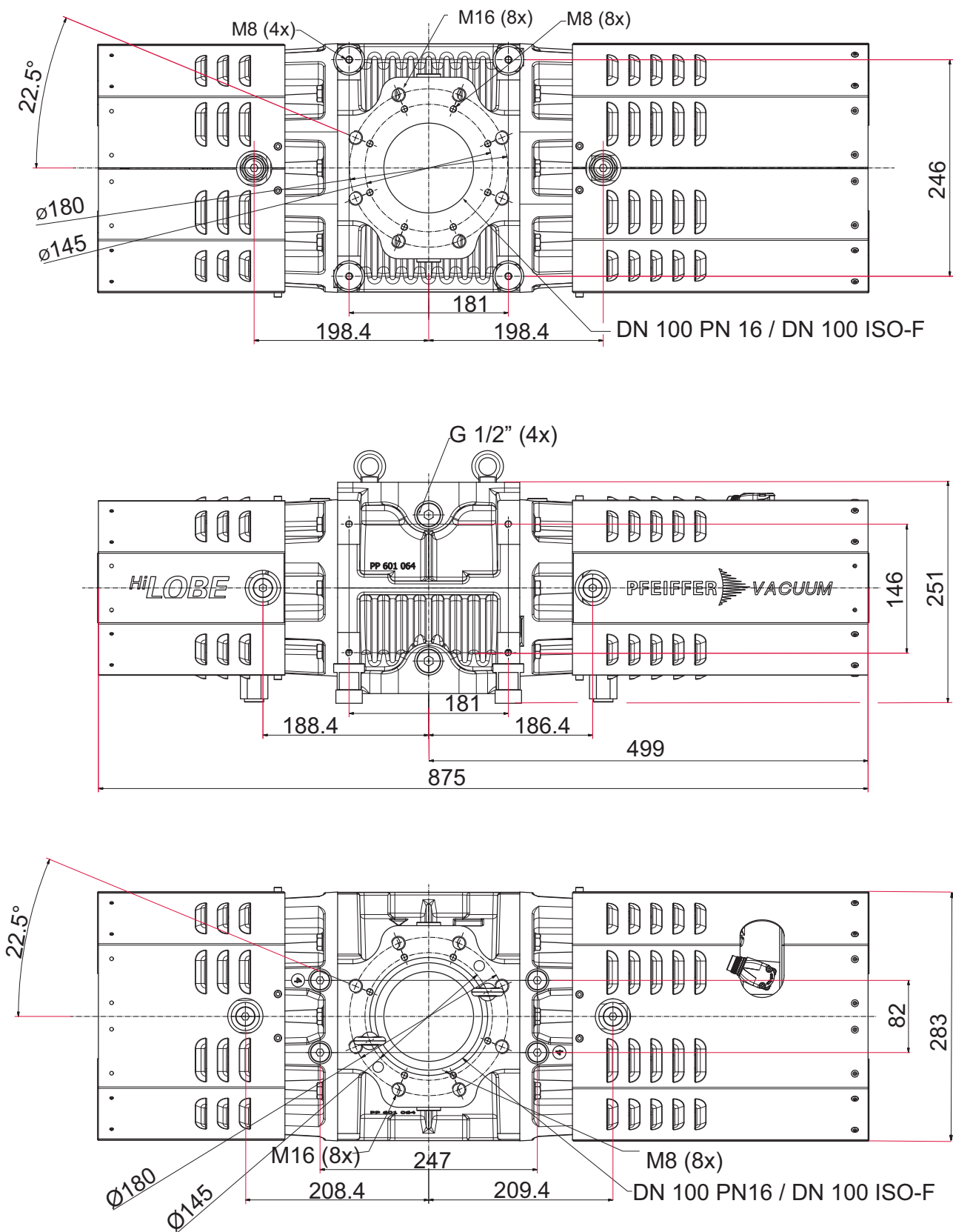

Fig. 19: HiLobe 1004, HiLobe 1304, HiLobe 2104 | DN 100



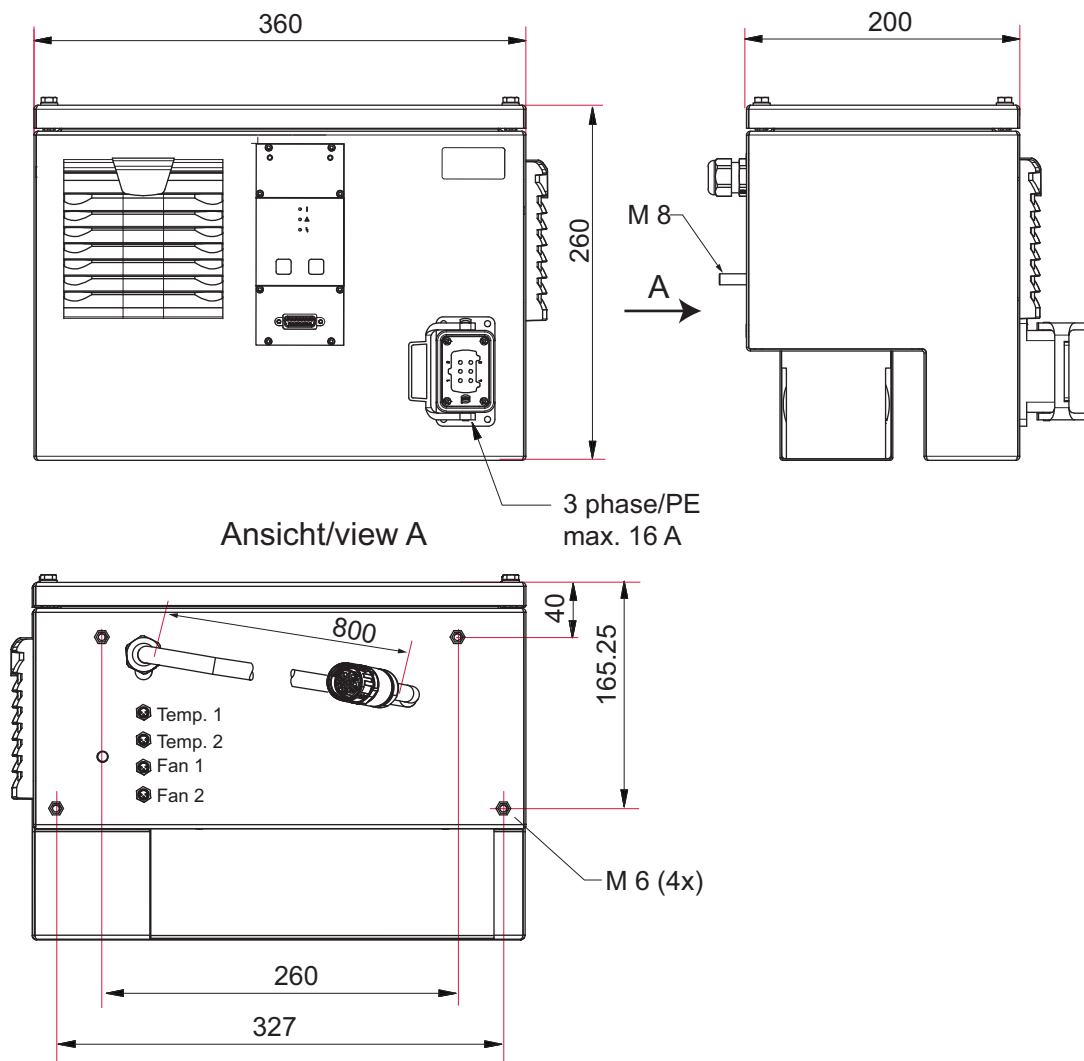

Fig. 20: RC 4000 electronic drive unit



Declaration of conformity

Declaration for product(s) of the type:

Roots pump

HiLobe 1004

HiLobe 1304

HiLobe 2104

HiLobe 1004 H

HiLobe 1304 H

HiLobe 2104 H

We hereby declare that the listed product satisfies all relevant provisions of the following **European Directives**.

- **Machinery 2006/42/EC (Annex II, no. 1 A)**
- **Electromagnetic compatibility 2014/30/EU**
- **Restriction of the use of certain hazardous substances 2011/65/EU**
- **Restriction of the use of certain hazardous substances, delegated directive 2015/863/EU**

Harmonized standards and applied national standards and specifications:

DIN EN ISO 12100: 2011

DIN EN 61010-1: 2011

DIN EN 1012-2: 2011-12

DIN EN 61000-3-11

DIN EN ISO 13857: 2008

DIN EN 61000-3-12

DIN ISO 21360-1: 2016

DIN EN 61000-6-2: 2006

ISO 21360-2: 2012

DIN EN 61000-6-4: 2007

DIN EN ISO 2151: 2009

DIN EN 60529: 2014

DIN EN 60204-1: 2014

DIN EN IEC 63000: 2019

The authorized representative for the compilation of technical documents is Mr. Sebastian Oberbeck, Pfeiffer Vacuum GmbH, Berliner Straße 43, 35614 Asslar, Germany.

Signature:



Pfeiffer Vacuum GmbH
Berliner Straße 43
35614 Asslar
Germany

(Daniel Sälzer)
Managing Director

Asslar, 2019-10-14





VACUUM SOLUTIONS FROM A SINGLE SOURCE

Pfeiffer Vacuum stands for innovative and custom vacuum solutions worldwide, technological perfection, competent advice and reliable service.

COMPLETE RANGE OF PRODUCTS

From a single component to complex systems:

We are the only supplier of vacuum technology that provides a complete product portfolio.

COMPETENCE IN THEORY AND PRACTICE

Benefit from our know-how and our portfolio of training opportunities!

We support you with your plant layout and provide first-class on-site service worldwide.

ed.A - Date 1910 - P/N:PW0329BEN



Are you looking for a
perfect vacuum solution?
Please contact us

Pfeiffer Vacuum GmbH
Headquarters • Germany
T +49 6441 802-0
info@pfeiffer-vacuum.de

www.pfeiffer-vacuum.com

PFEIFFER  **VACUUM**



蒙天真空
MT VACUUM